



WWW.BURCAM.COM

2190 Boul. Dagenais West
LAVAL (QUEBEC)
CANADA
H7L 5X9

TEL: 514.337.4415
FAX: 514.337.4029
info@burcam.com

INSTALLATION INSTRUCTIONS

MODEL 300402

SUMP BUDDY

Please read these instructions carefully. **Failure** to comply to instructions and **designed** operation of this system, may **void** the warranty.

**ELECTRICAL PUMP
AND PIPING NOT
INCLUDED**



Your pump has been carefully packaged at the factory to prevent damage during shipping. However, occasional damage may occur due to rough handling. **Carefully inspect your pump** for damages that could cause failures. Report any damage to your **carrier or your point of purchase.**

SAFETY INSTRUCTIONS:(applicable to your electrical primary pump)

This fine pump that you have just purchased is designed from the latest in material and workmanship.

Before installation and operation, we recommend the following procedures:

- A** CHECK WITH YOUR LOCAL ELECTRICAL AND PLUMBING CODES TO ENSURE YOU COMPLY WITH THE REGULATIONS. THESE CODES HAVE BEEN DESIGNED WITH YOUR SAFETY IN MIND. BE SURE YOU COMPLY WITH THEM.
- B** WE RECOMMEND THAT A SEPARATE CIRCUIT BE LEAD FROM THE HOME ELECTRICAL DISTRIBUTION PANEL PROPERLY PROTECTED WITH A FUSE OR A CIRCUIT BREAKER. WE ALSO RECOMMEND THAT A GROUND FAULT CIRCUIT BE USED. CONSULT A LICENSED ELECTRICIAN FOR ALL WIRING.
- C** THE GROUND TERMINAL ON THE THREE PRONG PLUGS SHOULD NEVER BE REMOVED. THEY ARE SUPPLIED AND DESIGNED FOR YOUR PROTECTION.
- D** NEVER MAKE ADJUSTMENTS TO ANY ELECTRICAL APPLIANCE OR PRODUCT WITH THE POWER CONNECTED. DO NOT ONLY UNSCREW THE FUSE OR TRIP THE BREAKER, REMOVE THE POWER PLUG FROM THE RECEPTACLE.
- E** ASSUMING THAT YOU HAVE A SUMP PIT LOCATED IN YOUR BASEMENT FLOOR... YOUR SUMP PIT SHOULD BE CONSTRUCTED FROM CONCRETE, BRICK, TILE OR MORE RECENTLY A SUMP BASIN MADE FROM PLASTIC AND/OR FIBERGLASS. THE MINIMUM SIZE OF YOUR SUMP PIT MUST BE 18" IN DIAMETER AND NO LESS THAN 25" DEEP. WHEN PIT IS READY, PROCEED TO NEXT STEP.

Material required for emergency sump pump application

Pump installation

- Municipal water source with a minimum of 40 PSI and a maximum of 60 PSI.
- Desired length of copper pipe and required fittings to link up municipal water source to sump buddy automatic valve.
- Teflon tape.
- Desired length of polyethylene pipe and T or Y fitting, to link up sump buddy discharge to existing discharge of electrical sump pump.

Tools

- Screwdrivers, hacksaw to cut pipe, knife to assist in pipe cutting, round file to smooth pipe ends, pipe wrench, adjustable wrench to tighten fittings, propane torch and welding material.

APPLICATION

This pump is designed to be connected to any existing conventional type sump pump system, as an extra sump pump protection.

CAPACITY AT 60 PSI
(municipal water pressure):

5'	581 US GPH	Friction loss
10'	317 US GPH	in pipe
15'	158 US GPH	not included

FEATURES

- Extra protection during power outage or in the event of failure of conventional sump pump.
- Easy to connect to existing conventional sump pump discharge line.
- Automatic control valve activate the SUMP BUDDY.
- No electricity required.
- No battery required.

INSTALLATION STEPS

(see diagram on page 5)

STEP 1 We recommend that you install your SUMP BUDDY in a location where there is adequate room for servicing at a later date. Discharge line should be made from ABS or PVC 1 1/4", 1 1/2" or 2" pipe.

We do not recommend to install flexible drain kit due to friction loss. Head capacity and/or discharge flow will be reduce in a large proportion.

Use teflon tape on all connections.

Keep suction screen and ejector clean.

Check regularly your SUMP BUDDY to ensure its proper operation. Remember that solids or debris in water should be removed from the sump pit.

STEP 2 Remove electrical power of your existing conventional sump pump and verify that this sump pump is equipped with a check valve at pump discharge. If not, add a check valve before continuing your installation. The sump pump check valve should be located at the primary pump discharge and installed below the "Y" fitting.

STEP 3 Locate your SUMP BUDDY in an ideal position and cut the existing discharge line to install the T or Y fitting. Cut the desired length of pipe to connect the discharge line from the check valve of the SUMP BUDDY to the T or Y fitting.

STEP 4 Run this discharge line with fittings to adjust your SUMP BUDDY in vertical position. We recommend that the distance between the bottom of the SUMP BUDDY and the bottom of the sump pit be approximately 2".

Check valve required
as per step 2.
350353 1 1/2"



STEP 5 Close municipal water supply. Run a supply line (not less than 1/2", 3/4" recommended) to the ideal position for an easy operation of the automatic control valve of the SUMP BUDDY. Install a ball valve near the pump area, to close water supply for servicing at a later date.

STEP 6 Flush this new line, before next step, to remove any debris which may obstruct the water flow in your SUMP BUDDY.

STEP 7 Screw the automatic control valve to the supply line.

STEP 8 Install the 90° galvanized bracket to the automatic control valve by using the two screws supplied.

STEP 9 Install the stainless steel rod by simply screwing the two parts together. Using the large coupling, secure the rod connection. The top screw is to secure the top part and the bottom screw is to secure the bottom part of the rod.

STEP 10 The next step is to install the float by simply passing the rod through the float opening. Then use the small couplings to secure the float to the rod by simply screwing the unit to the rod.

STEP 11 The float should be set at least 2" higher than the conventional electrical pump setting, so that the back-up pump will not start prior to the main electrical pump. To complete the float installation, simply insert the stainless steel rod through the 90° bracket, then install a rubber grommet below the control valve level, then insert the shaft through the control valve and insert the second grommet on the top, then set the grommet adjustment to the proper location to properly adjust the setting.

STEP 12 Fix the vacuum breaker to the automatic control valve and screw the connecting hose.

STEP 13 Adjust the length of the connecting hose and fix it to the sump buddy with a clamp.

STEP 14 You are now ready to test your SUMP BUDDY. Restart municipal water supply, and confirm that there are no leaks in supply line. Try the automatic control valve by drawing up the lever. Water will go through the SUMP BUDDY. Push down the lever to shut off water flow.

STEP 15 Fill the sump pit with water. Verify the action of the automatic control valve and the level of water to start your SUMP BUDDY, then repeat the operation many times.

STEP 16 Turn on electrical power of the conventional sump pump and verify the entire system.

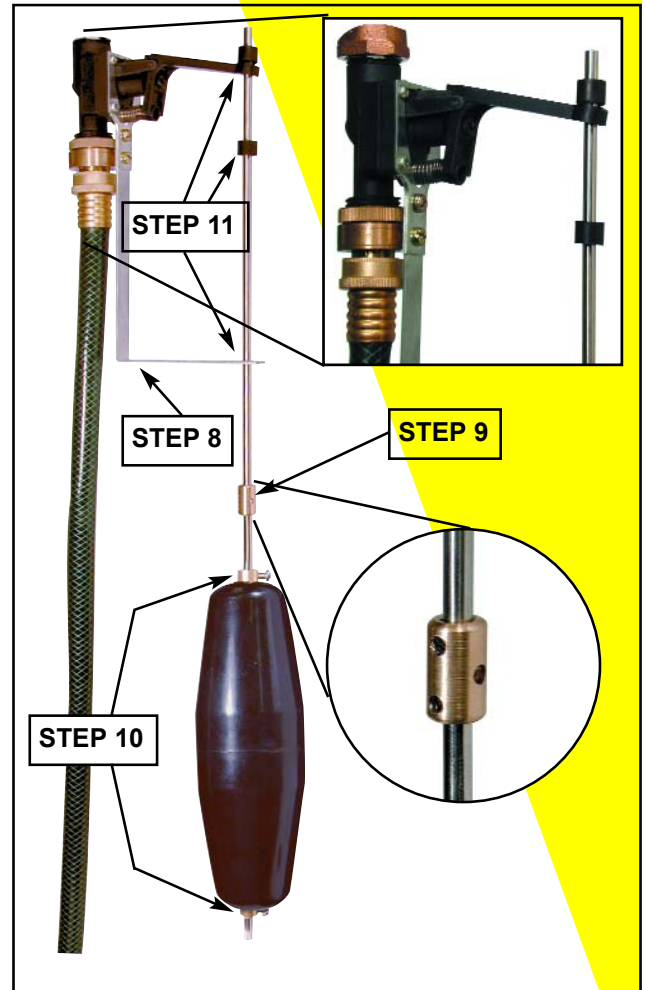

TYPICAL INSTALLATION DIAGRAM FOR SUMP PUMP

STEP 1
Install with solid discharge line from 1 1/4" to 2" pipe size.

STEP 3
Install T or Y fitting and link discharge lines together.

This ejector is press fit fixed. Do not try to unscrew, you will damage and void warranty. Please call us to make maintenance at 1-800 361-1820.

STEP 4
Adjust in vertical position and leave 2" under SUMP BUDDY.

STEP 13
Adjust length of connecting hose.

STEP 6
Flush line to remove debris.

STEP 5
Run a supply line with a ball valve near pump area.

STEP 11
Install float and rod to automatic valve.

STEP 7
Screw automatic control valve.

STEP 12
Fix vacuum breaker.

STEP 8
Install the float bracket.

STEP 9
Assemble float rod.

STEP 2
Remove electrical power and verify for check valve.

STEP 10
Install float.

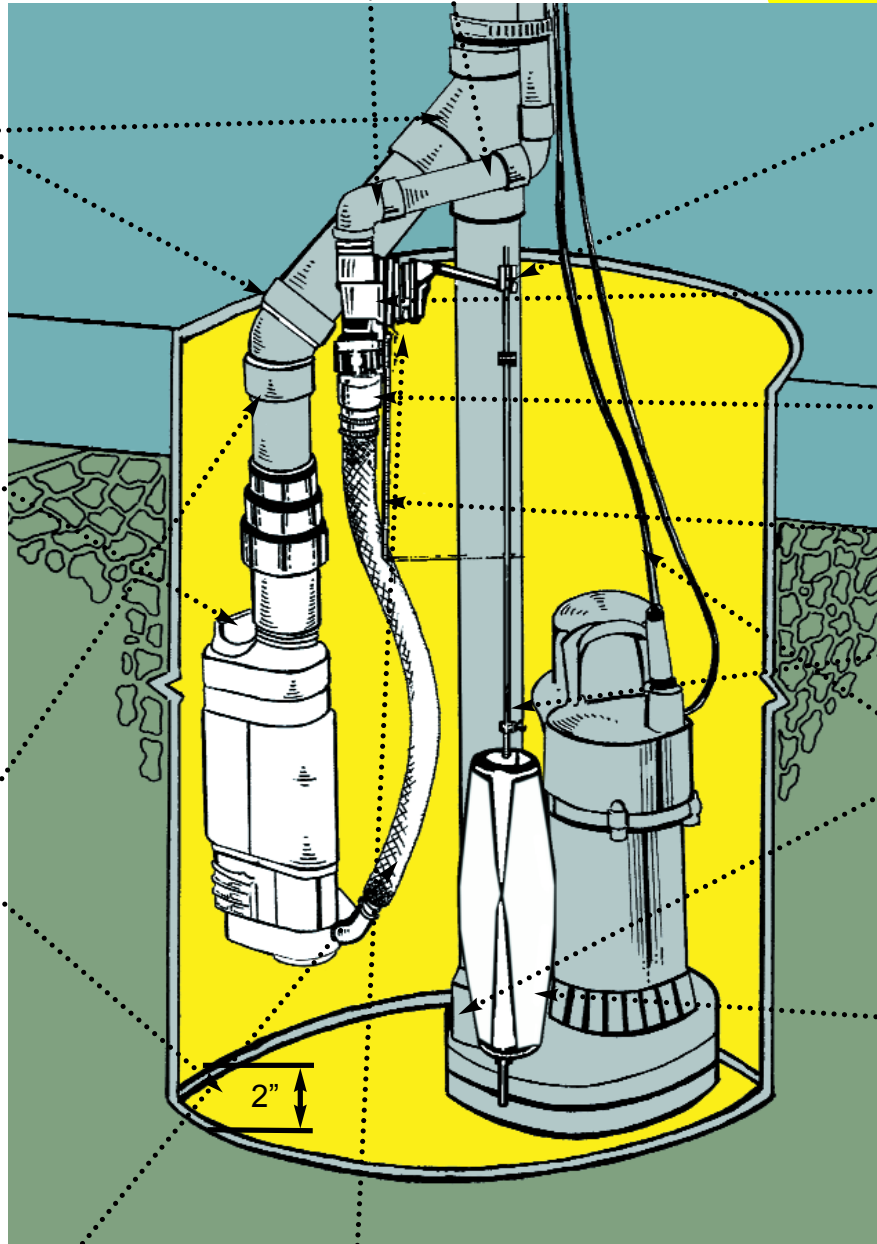

STEP 14
Test manually automatic control valve operation.

STEP 15
Fill pit with water. Verify automatic action and starting level.

STEP 16
Turn on electrical power of conventional sump pump.

TYPICAL INSTALLATION DIAGRAM FOR COLUMN PUMP

STEP 1
Install with solid discharge line from 1 1/4" to 2" pipe size.

STEP 3
Install T or Y fitting and link discharge lines together.

This ejector is press fit fixed. Do not try to unscrew, you will damage and void warranty. Please call us to make maintenance at 1-800 361-1820.

STEP 4
Adjust in vertical position and leave 2" under SUMP BUDDY.

STEP 6
Flush line to remove debris.

STEP 5
Run a supply line with a ball valve near pump area.

STEP 11
Install float and rod to automatic valve.

STEP 7
Screw automatic control valve.

STEP 12
Fix vacuum breaker.

STEP 8
Install the float bracket.

STEP 9
Assemble float rod.

STEP 2
Remove electrical power and verify for check valve.

STEP 10
Install float.

STEP 13
Adjust length of connecting hose.

STEP 14
Test manually automatic control valve operation.

STEP 15
Fill pit with water. Verify automatic action and starting level.

STEP 16
Turn on electrical power of conventional sump pump.

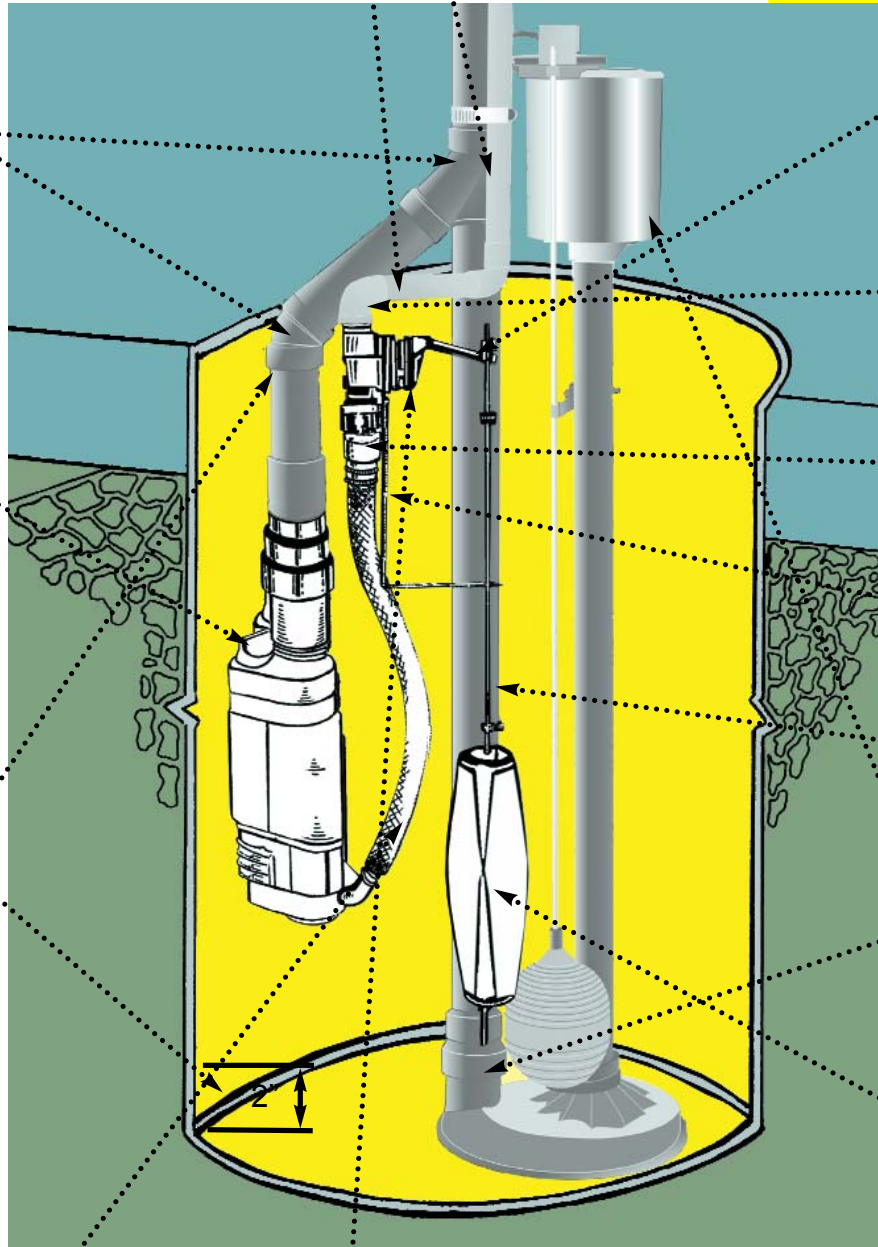

REPAIR PARTS LIST

REF.	PART	DESCRIPTION
1	350250	Pump body
2	350254K	Ejector kit (incl.#3, 4,5,6)
3	350255	Ejector seal
4	350254	Ejector
5	350256	Ejector "O" ring
6	350257	Ejector "O" ring
7	350353A	ABS check valve 1 1/4"
8	350253	Coupling
9	350252	Hose clamp
10	350251	Connecting hose
11	350260	Back flow preventor
12	350267	Automatic valve & bracket
13	350248	Screws
14	350247	90° float guide
15	350246	Rubber stop
16	350245	Stainl. steel float rod
17	350244	Connection screws (2)
18	350243	Adjustment couplings (2)
19	350266	Float
20	350241	Rod coupling
21	350242	Screws (4) for rod
22	350265	Float/valve assembly (incl. # 11 to 21)

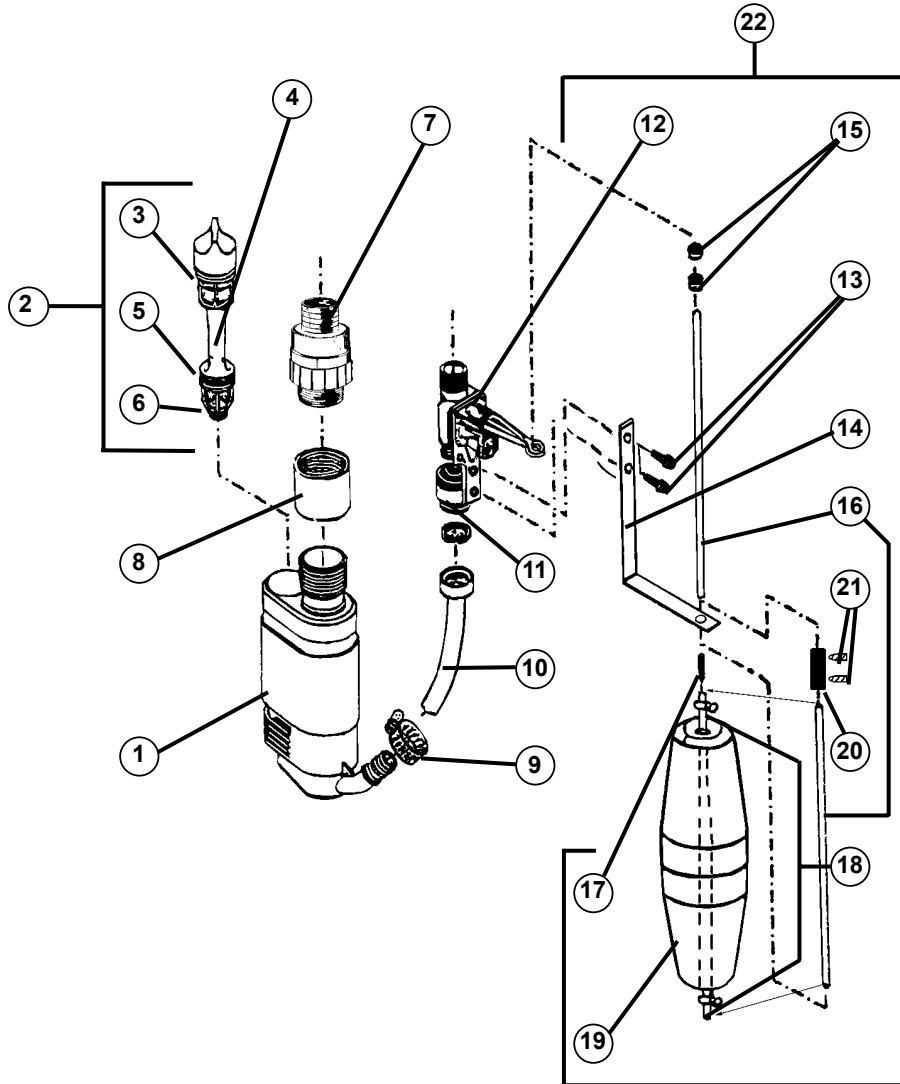

7

REPAIR PARTS MAY BE ORDERED FROM YOUR AUTHORIZED POINT OF SALE OR FROM BUR-CAM PUMPS

TROUBLE SHOOTING GUIDE CHECKLIST

NEVER MAKE ADJUSTMENTS TO ANY ELECTRICAL APPLIANCE OR PRODUCT WITH THE POWER CONNECTED. DON'T JUST UNSCREW THE FUSE OR TRIP THE BREAKER, REMOVE THE POWER FROM THE RECEPTACLE.

TROUBLE	PROBABLE CAUSE	ACTION
No water is drawn out.	<p>Municipal water supply closed. Automatic valve closed. Float do not rise with water level. Suction or ejector clogged. Water level below suction in sump.</p> <p>Improper function or missing check valve in primary pump discharge. Discharge line clogged. Pumping height more than 15 ft. Municipal water pressure under 40 PSI.</p>	<p>Turn on ball valve. Check manually the valve operation. Check for obstruction of float action. Clean. Adjust the float rod to shut off pump prior to low water level. Install a check valve below the "Y" fitting on your primary pump discharge base. Check all pipes. Reduce top lift to less than 15 ft.head. Run a 3/4" direct line from municipal water supply to reduce friction loss in pipe.</p>
Pump does not pump water to full capacity.	<p>Municipal water supply partially opened. Automatic valve partially opened. Suction or ejector partially clogged. Leaky primary pump check valve. Discharge line partially clogged.</p>	<p>Turn on ball valve. Check manually the valve operation. Clean. Replace. Check all pipes.</p>
Pump does not shut off.	<p>Automatic valve does not shut off. Float is obstructed</p>	<p>Check manually the valve operation. Check for obstruction or adjust rubber grommet to proper off and on position.</p>

TO THE END CONSUMER

If you have any problems with the product, before advising the store, where you've purchased the pump, please contact us at 514 337-4415 , and ask for our sales department, and they will be pleased to help you with any questions you might have, concerning your installation.