

LIMITED WARRANTY AND LIMITATION OF LIABILITY

Decko Products warrants this product free from material and/or manufacturing defects for one year from date of purchase (three years on select cast iron pumps). As the sole and exclusive remedy for a breach of this limited warranty, if the product is found by Decko Products to be defective, Decko Products, at its option, will refund the purchase price or replace the product with an equivalent product if it is returned to the place of purchase or returned postpaid to Decko Products, ATTN: Warranty Dept., 2808 North Fairview Ave., Roseville, MN 55113, with proof of purchase. Any disassembly, modification, or abuse of this product voids this limited warranty. This product is not designed for pumping flammable or corrosive fluids, and use of this product to pump such materials also voids this limited warranty.

**DECKO PRODUCTS DISCLAIMS ALL OTHER
EXPRESS OR IMPLIED WARRANTIES,
INCLUDING WARRANTIES OF
MERCHANTABILITY OR FITNESS FOR A PARTICULAR PURPOSE.**

IMPORTANT NOTICE: Some commercial and residential insurance policies extend coverage for damages incurred by product failure. In most cases, you will need to have possession of the product to support your claim. In the case where you need to retain possession of the product to support a damage claim you submit to your insurance company, Decko Products will exchange the unit or refund the original price once the claim is settled with the insurer.



**2805 North Fairview Ave.
Roseville, MN 55113
1-800-495-9278
www.superiorpumpco.com**



OWNER'S MANUAL

**INSTALLATION AND OPERATION
INSTRUCTIONS FOR**

**RTG/PB SERIES
SUBMERSIBLE SUMP PUMPS**

Models:

**92341-RTG-A, 92342-RTG-A, 92352-RTG-A, 92511-RTG-A
92341-RTG-P, 92342-RTG-P, 92352-RTG-P, 92511-RTG-P
92341-PB, 92342-PB, 92352-PB, 92511-PB**



If for any reason you have questions concerning your new Superior Pump, call us toll free at 1-800-495-9278, or contact us on the web at www.superiorpumpco.com

Carefully read and understand all of the Warnings and installation instructions in this manual. Failure to follow these instructions could lead to serious bodily injury and/or property damage. Retain these instructions for future reference.

This pump has been manufactured with your needs in mind. Properly installed in the right application, your new Superior Pump will give you years of carefree performance.

DANGER ⚠ Water and electricity can be dangerous if certain precautions are not adhered to. This pump is designed to operate perfectly safe in a water environment; however, improper use and installation can result in personal harm from electrical shock. Please pay attention to the following warnings.

WARNING ⚠ Never touch any electrical device, including this pump, when it is touching water, in water, or even in a moist environment. Always unplug (disconnect the electricity) when working on or installing the unit.

WARNING ⚠ **RISK OF ELECTRICAL SHOCK.** This pump is supplied with a grounding conductor and grounding-type attachment plug. To reduce the risk of electrical shock, be certain that it is connected only to a properly grounded, grounding-type receptacle.

WARNING ⚠ Do not use the power cord or discharge hose to carry or handle the pump. Doing so may cause damage to the power cord or discharge hose. Use the carrying handle supplied with the pump.

WARNING ⚠ Always use a grounded outlet. A three-prong mating type receptacle is needed for safe use. This should be in accordance with the National Electric Code and any additional codes or laws required by your local government.

NOTICE ⚠ It is strongly recommended to use a ground fault interrupt device on any electrical appliance, including this pump, when used in a wet or moist environment. This is required by many local codes and enforcement agencies. It is strongly recommended by Decko Products as it provides a much safer installation and will greatly reduce possible injury from electrical shock.

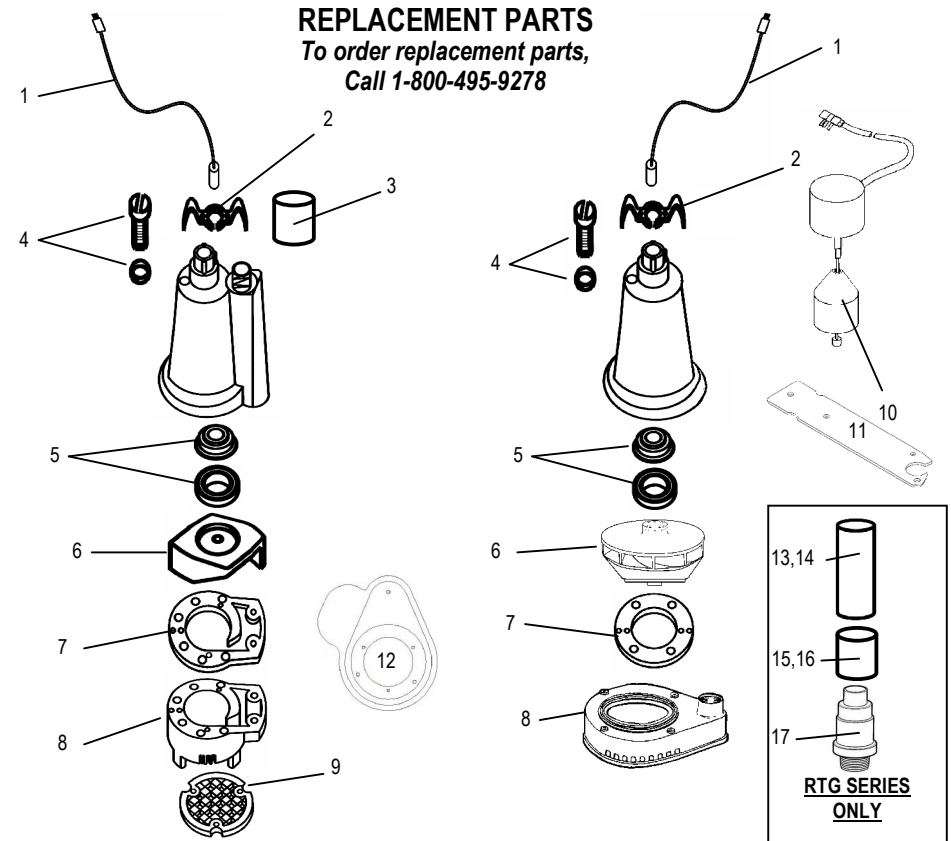

Ref	Description	PART # FOR MODELS:		
		92342-RTG-A&P 92342PB	92341-RTG-A&P 92341PB	92352-RTG-A&P 92511-RTG-A&P 92352PB 92511PB
1	Power Cord	99008		
2	Handle	99050	99050	99050
3	Hose Coupling	99007	99007	
4	Oil Fill Plug with O-ring	99055	99056	99056
5	Shaft Seal	99057	99057	99057
6	Impeller	99065	99065	99070
7	Gasket	99062	99062	99064
8	Volute/Base	99069	99070	99071
9	Intake Screen	99073	99073	99074
10	Float Switch	92010	92010	92010
11	Vertical float Switch Bracket	99105	9910	99105
12	Plastic Base	99500	99500	99500
13	1 1/2" ABS Pipe (RTG Series only)	99512	99512	99515
14	1 1/2" PVC Pipe (RTG Series only)	99516	99516	99518
15	1 1/2" ABS Coupling (RTG Series only)	99510	99510	99510
16	1 1/2" PVC Coupling (RTG Series only)	99514	99514	99514
17	Check Valve (RTG Series only)	99507	99507	99509

NOTICE ⚠ Height and/or piping restriction will reduce the pump output performance. See the performance chart below to insure you have the proper pump for your application. Whenever possible use the same size or larger pipe as the pump discharge for optimum performance. Reducing the pipe size will not harm your pump; it will just reduce the output.

PERFORMANCE CHART

Model #-RTG, PB	Output in gallons per minute at listed discharge height above pumping level					
	0'	5'	10'	15'	20'	25'
92342, 92341	40	34	28	22	12	2
92352	60	56	50	35	15	6
92511	70	66	58	48	25	10

SPECIFICATIONS

Model # -RTG, PB	92342	92341	92352	92511
HP	1/3	1/3	1/3	1/2
Amps	4.1	4.1	7.6	7.6
Solids Handling	1/8"	1/8"	1/2"	1/2"
Warranty (Years)	1	3	3	3
Discharge Size	1 1/4"	1 1/4"	1 1/2"	1 1/2"

Power supply requirements..... 120V, 60 Hz (15 amp)
 Motor..... Continuous Duty, Capacitor Start, Thermally Protected
 Liquid Temperature Range..... 32° F - 120° F (0° C - 49° C)

DANGER ⚠ Do not use this pump to pump chemicals, flammable liquids, sewage or corrosive liquids. You could injure yourself and the pump will fail. Pumping these types of liquids voids the warranty. Decko Products and other pump companies manufacture pumps for these types of liquids. Make sure you purchase a pump designed for your specific needs. This pump will handle fluids with the same characteristics as water. If you have any questions call us at 1-800-495-9278 or contact us on the web at www.superiorpumpco.com

WARNING

Your pump has thermal over-load protection built in. It is not recommended for pumping liquids over 120° F. The thermal overload protector will automatically shut down the pump in an overheat situation. It will then reset itself once the pump cools down. This overload is designed as a safety device and it will fail after repeated use. Normal operation is for fluids between 32° F & 120° F.

DO NOT RUN THE PUMP DRY. The pump depends on water for cooling and lubrication. Operating the pump without water may cause the motor to overheat or cause damage to parts of the pump. It may also shorten the life of your pump.

NOTICE

EXTENSION CORDS

For best performance, it is recommended to connect the power cord directly to the grounded GFCI outlet. If the use of an extension cord is necessary, always use a grounded waterproof type cord. Never use longer than a 25-ft. cord that is lighter than 14/3 gauge.

DANGER ⚠ Keep all electrical connections away from wet and moist environments. Wet connections can cause electrical shock resulting in personal injury.

USE AND INSTALLATION

WARNING ⚠ ALWAYS DISCONNECT THE POWER SOURCE BEFORE ATTEMPTING TO INSTALL, SERVICE OR PERFORM MAINTENANCE ON THE PUMP. FAILURE TO DO SO MAY RESULT IN FATAL ELECTRICAL SHOCK.

Your Superior Pump is designed and built to give you reliable performance and long life. It will pump water automatically for years when properly installed in the right environment.

REMOVING OLD PUMP. (If necessary)

1. Make sure power supply is disconnected.
2. After the power is off, remove the old pump. There are many different possible types of installations.
3. It is best to remove all old piping and start over with new piping. Be sure to clean all debris and dirt out of the sump basin before installing your new pump.

Be sure to have a grounded 120V AC outlet mounted within 6 ft. of your sump basin. Again, it is highly recommended that a GFCI (ground fault circuit interrupter) outlet be installed in the receptacle box.

NOTICE ⚠ A qualified electrician must perform all wiring.

INSTALLATION (PB Series)

1. Set your new pump in the bottom of the sump basin off to one side. The pump should be placed on a solid foundation. Do not place the pump directly on the ground or sandy or rocky surfaces. Sand and small stones may clog or cause damage to your pump.
2. Make sure the float switch will swing freely from the bottom to top without coming in contact with the side of the sump basin. Contact with the side of the sump basin may cause the switch to malfunction. See figure below.

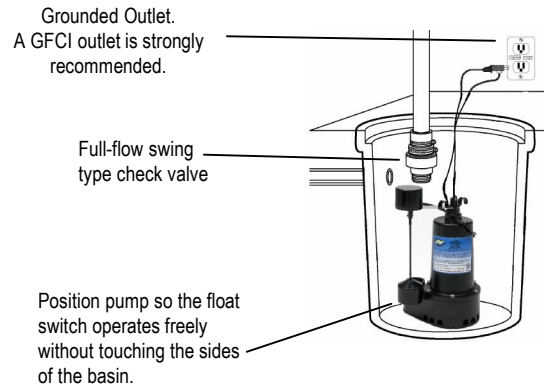

3. It is highly recommended to install a full flow, swing type check valve (not included with PB series pumps) as close to the discharge outlet on the pump as possible. A new check valve will greatly increase the life of your pump. The check valve should be the same size as the pump discharge.
4. Connect the pump and check valve together using schedule 40 PVC pipe and fittings. You can also use DWV or ABS pipe, as this is not a pressure installation. Corrugated drain hose is intended for temporary use and should not be used in a permanent installation. Although there are many types of pipe that work adequately for this installation, PVC or ABS is recommended.

INSTALLATION (RTG Series)

1. Set your new pump in the bottom of the sump basin off to one side. The pump should be placed on a solid foundation.
2. Simply connect the pipe from the pump to your existing discharge pipe.

Test your installation after you have completed setting up the pump. Plug the cord from the pump into the piggyback plug of the float switch, and then plug that into your grounded outlet. The pump should not run at this point. If the pump runs, the switch is stuck in the upright position or the pump is plugged directly into the outlet and not through the piggyback switch plug. Fill the sump basin with water using buckets or a hose. When the switch floats to the upright position, the pump will turn on. The switch will turn off the pump when it reaches the

down position. You may adjust the switch to meet your particular needs. The cut out (turn off) setting is the only adjustment available on vertical type switches.

TROUBLESHOOTING

WARNING  ALWAYS DISCONNECT THE POWER SOURCE BEFORE ATTEMPTING TO INSTALL, SERVICE OR PERFORM MAINTENANCE ON THE PUMP. FAILURE TO DO SO MAY RESULT IN FATAL ELECTRICAL SHOCK.

If the pump does not start or run.

1. Make sure pump is plugged in.
2. Check for blown fuses or tripped circuit breakers or tripped GFCI outlets.
3. Check pump by bypassing the switch and plugging the pump directly into the outlet. If pump works, there is a problem with the switch. Replace the switch.
4. Check for any obstructions in the impeller by removing intake screen and base.

If the pump starts and stops too often:

1. Check for backflow of water from discharge hose/pipe. Install or replace check valve.
2. Check float switch for proper operation. Replace if necessary.

If the pump will not shut off:

1. Make sure switch drops to full down position. It may be obstructed.
2. Check for obstructions in piping.

If the pump runs and moves little or no water

1. Make sure check valve is installed in correct direction.
2. Check to insure discharge pipe is not plugged.
3. Unit may be air locked. This pump has an anti-airlock device built in. Clean out airlock.
4. Check intake screen for obstructions, clean if necessary.