



## ALM-2 and ALM-2-1 Alarm System Installation Instructions

This alarm system monitors liquid levels in lift pump chambers, sump pump basins, holding tanks, sewage, agricultural, and other water applications.

The ALM-2 and ALM-2-1 alarm systems can serve as a high or low level alarm depending on the float switch model used. The alarm horn sounds when a potentially threatening liquid level condition occurs. The horn can be turned off, but the alarm light remains on until the condition is remedied. Once the condition is cleared the alarm will automatically reset. A green "power on" light indicates 120 VAC primary power to the alarm. Low battery chirp feature indicates when battery should be replaced.

### FEATURES



- **120 VAC Model Voltage** - (circuits not supervised) Primary: 120 VAC, 60 Hz, 2.4 watts maximum (alarm condition) Operating Voltage: 9 VDC  Double insulation.
- NEMA 1 enclosure rated for indoor use.
- Automatic alarm reset.
- Red "alarm" light and green "power on" light, alarm "test" switch, and horn "silence" switch.
- 6 foot (1.8 meter) power cord.
- Alarm horn sounds at 87 decibels at 10 feet (3 meters).
- Can be used with any UL Listed switching mechanism rated to include 1 amp, 9 VDC load.
- Maximum line impedance for initiating device: 5 ohms.
- If primary power fails, the alarm system continues to work due to battery backup feature. Battery Backup Power - (circuit not supervised) 9 VDC.
- Complete package includes standard SJE SignalMaster® control switch with 10 (ALM-2-1) or 20 (ALM-2) feet of cable, mounting clamp, and cord bung.
- Switching mechanism operates on low voltage and is isolated from the power line to reduce the possibility of shock.
- Low battery chirp.
- External terminal block for easy float switch installation.
- Three-year limited warranty.

### PREVENTATIVE MAINTENANCE

- Periodically inspect the product. Check that the cable has not become worn or that the housing has not been damaged so as to impair the protection of the product. Replace the product immediately if any damage is found or suspected.
- Periodically check to see that the float is free to move and operate the switch.
- Use only SJE-Rhombus® replacement parts.

### LIBERTY PUMPS® THREE-YEAR LIMITED WARRANTY

Liberty Pumps, Inc. warrants that products of its manufacture are free from all factory defects in material and workmanship for a period of 3 years from the date of purchase. The date of purchase shall be determined by a dated sales receipt noting the model and serial number. The dated sales receipt must accompany the returned product if the date of return is more than 3 years from the date of manufacture noted on the product.

The manufacturer's obligation under this Warranty shall be limited to the repair or replacement of any parts found by the manufacturer to be defective, provided the part or assembly is returned freight prepaid to the manufacturer or its authorized service center, and provided that none of the following warranty-voiding characteristics are evident:

The manufacturer shall not be liable under this Warranty if the product has not been properly installed; if it has been disassembled, modified, abused or tampered with; if the electrical cord has been damaged or improperly spliced; if the pump discharge has been reduced in size; if the pump has been used in hot water or water containing sand, lime, cement, gravel, or

other abrasives; if the product has been used to pump chemicals or hydrocarbons; if a non-submersible motor has been subject to excessive moisture; or if the label bearing the serial and code number has been removed.

Liberty Pumps, Inc. shall not be liable for any loss, damage or expenses resulting from installation or use of its products, or for consequential damages, including costs of removal, reinstallation or transportation.

There is no other express warranty. All implied warranties, including those of merchantability and fitness for a particular purpose, are limited to three years from date of purchase.

The Warranty contains the exclusive remedy of the purchaser, and, where permitted, liability for consequential or incidental damages under any and all warranties are excluded.

**⚠ WARNING****ELECTRICAL SHOCK HAZARD**

Disconnect power before installing or servicing this product. A qualified service person must install and service this product according to applicable electrical and plumbing codes.

**⚠ WARNING****EXPLOSION OR FIRE HAZARD**

Do not use this product with flammable liquids. Do not install in hazardous locations as defined by National Electrical Code, ANSI/NFPA 70.

Failure to follow these precautions could result in serious injury or death. Replace product immediately if switch cable becomes damaged or severed. Keep these instructions with warranty after installation. This product must be installed in accordance with National Electric Code, ANSI/NFPA 70 so as to prevent moisture from entering or accumulating within boxes, conduit bodies, fittings, float housing, or cable.

*For detailed specifications on this product, or for the complete line of Liberty Pumps® products, visit our web site at [www.libertypumps.com](http://www.libertypumps.com).*

**INSTALLING THE ALARM & FLOAT SWITCH**

1. Determine indoor mounting location for alarm.
2. Insert screw (supplied) at desired wall location.  
**Note:** Screw is to be located over wall stud or used with a wall anchor sized for a #8 x 1.25" self tapping screw.
3. Hang alarm using keyhole on back of enclosure. Install second screw in mounting flange located on bottom of alarm.
4. Make sure power to alarm is disconnected.
5. Place the float switch cord into the clamp as shown in Figure A.

6. Locate the clamp at the desired activation level and secure the clamp to the discharge pipe as shown in Figure A.  
**Note:** Do not install cord under hose clamp.
7. Tighten the hose clamp using a screwdriver. Over tightening may result in damage to the plastic clamp. Make sure the float cable is not allowed to touch the excess hose clamp band during operation.

**Note:** All hose clamp components are made of 18-8 stainless steel material. See your Liberty Pumps® supplier for replacements.

8. Bring cable leads back to alarm and wire according to Figure B. A cord bung is included with the kit.

**Note:** When used with a pump application, connect alarm to a circuit separate from the pump circuit. This allows the alarm to operate if the pump circuit fails.

9. Open battery door and install 9 VDC alkaline battery (not included). **Battery must be installed for backup alarm to function.** **Note:** The green power on light does not come on when unit is on battery power.
10. Plug the alarm in to apply primary power. Verify that the green "power on" light illuminates.

11. Check installation by manually tipping the float. The horn will sound and the "alarm" light should come on.

12. Press "silence" button to silence the horn. The horn will silence while the red "alarm" light stays on.

13. Tip float back down and press "test" button. The "alarm" light and horn will activate.

14. Test unit once a week. **Replace battery every 12 months and after each alarm condition** to ensure proper operation. If battery is low, low battery chirp feature will cause the horn to chirp approximately once per minute. Replace battery when this happens.

15. Using the provided cable clasp, secure cord to outlet as shown in Figure C. Use existing receptacle faceplate screw and supplied washer.

16. Test unit once per week to insure proper operation.

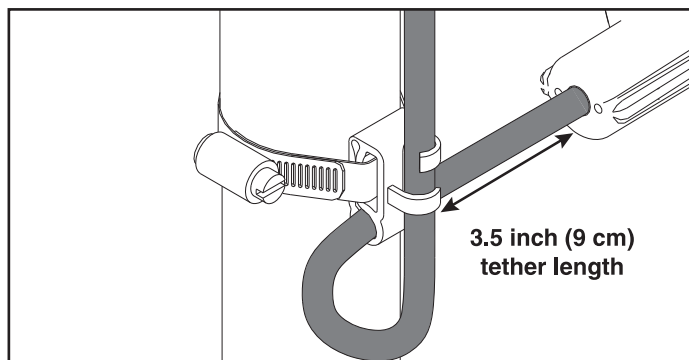
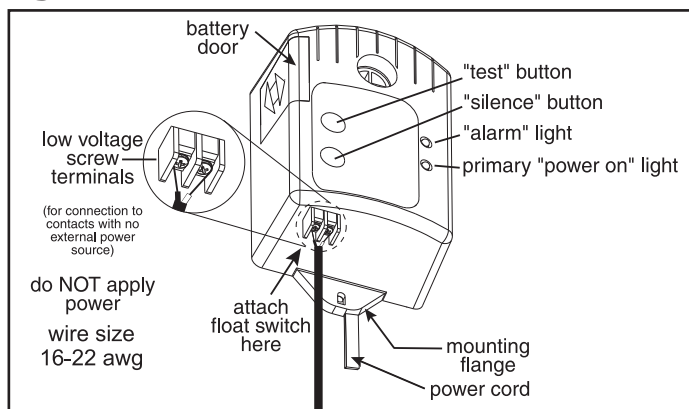
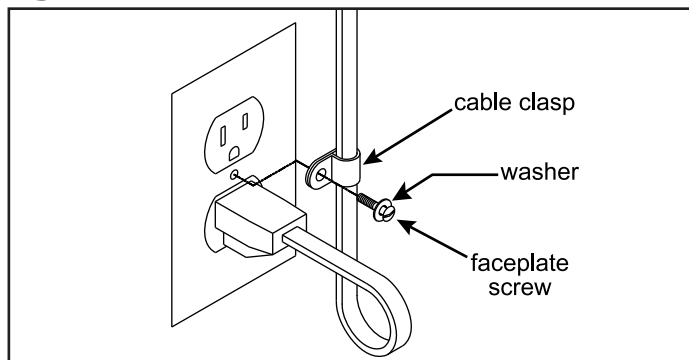
**Figure A****Figure B****Figure C**

# Liberty Pumps®

7000 Apple Tree Avenue ■ Bergen, New York 14416 USA ■ Phone: 1-800-543-2550

[www.libertypumps.com](http://www.libertypumps.com)

©SJE-Rhombus 06/12  
Instl. Instr. PN 1017740D  
Model TAAB