



WWW.BURCAM.COM

2190 Boul. Dagenais West
LAVAL (QUEBEC)
CANADA
H7L 5X9

TEL: 514.337.4415
FAX: 514.337.4029
info@burcam.com

INSTALLATION INSTRUCTIONS

MODEL 300828

SUBMERSIBLE SUMP PUMP

Your pump has been carefully packaged at the factory to prevent damage during shipping. However, occasional damage may occur due to rough handling. Carefully inspect your pump for damages that could cause failures. Report any damage to your carrier or your point of purchase.

Please read these instructions carefully. **Failure** to comply to instructions and **designed** operation of this system, may **void** the warranty.



SAFETY INSTRUCTIONS:

This fine pump that you have just purchased is designed from the latest in material and workmanship.

Before installation and operation, we recommend the following procedures:

- A** CHECK WITH YOUR LOCAL ELECTRICAL AND PLUMBING CODES TO ENSURE YOU COMPLY WITH THE REGULATIONS. THESE CODES HAVE BEEN DESIGNED WITH YOUR SAFETY IN MIND. BE SURE YOU COMPLY WITH THEM.
- B** WE RECOMMEND THAT A SEPARATE CIRCUIT BE LEAD FROM THE HOME ELECTRICAL DISTRIBUTION PANEL PROPERLY PROTECTED WITH A FUSE OR A CIRCUIT BREAKER. WE ALSO RECOMMEND THAT A GROUND FAULT CIRCUIT BE USED. CONSULT A LICENSED ELECTRICIAN FOR ALL WIRING.
- C** THE GROUND TERMINAL ON THE THREE PRONG PLUGS SHOULD NEVER BE REMOVED. THEY ARE SUPPLIED AND DESIGNED FOR YOUR PROTECTION.
- D** NEVER MAKE ADJUSTMENTS TO ANY ELECTRICAL APPLIANCE OR PRODUCT WITH THE POWER CONNECTED. DO NOT ONLY UNSCREW THE FUSE OR TRIP THE BREAKER, REMOVE THE POWER PLUG FROM THE RECEPTACLE.

Material required for submersible sump pump application

Submersible sump pump installation

- Desired length of 1 1/2" or 1 1/4" of ABS/DWV pipe to link up the pump to the drain line.
- 1 only 1 1/4" check valve (350353) (Note that this 1 1/4" check valve may also be use with a 1 1/2" pipe).
- Sump pit or 1 only sump basin.
- 1 1/4"-1 1/2" stainless steel clamps (750886).
- ABS cement.

Tools

Screwdrivers, hacksaw to cut pipe, knife to assist in pipe cutting, round file to smooth pipe ends, pipe wrench, adjustable wrench to tighten fittings.

NOTICE

This unit is not designed for applications to pump salt water or brine .
Use with salt water or brine will void warranty.

APPLICATION		FEATURES	
<input type="checkbox"/> This submersible sump pump is designed for a permanent sump installation. <input type="checkbox"/> To be used in a residential cottage and farm application.		<input type="checkbox"/> water cooled continuous duty motor. <input type="checkbox"/> Thermal and overload protection.	
<input type="checkbox"/> CAPACITIES:	<div style="border: 1px solid black; padding: 2px; display: inline-block;"> FRICTION LOSS IN PIPE NOT INCLUDED </div>	<input type="checkbox"/> Piggy back grounded cables <input type="checkbox"/> 115VAC, 60Hz. 1/3 HP, 7.4A.	
5'	2400		
10'	1600		
15'	900		
20'	300	US GPH	

INSTALLATION STEPS

STEP 1 We recommend that you install your pump in a clean location where there is adequate room for servicing at a later date. Protection from freezing temperatures and good ventilation should be considered as well, to provide the pump an environment for long life. **Do not use to pump gas or toxic fuels. This submersible sump pump is designed to pump water only.**

Friction losses in the discharge pipe must be taken into consideration when the horizontal offset is greater than 50 feet. The discharge pipe should be increased from 1 1/2" to 2". This will reduce friction losses and allow the pump to give maximum performance.

More friction losses must also be taken into consideration when many elbows and fittings are installed in the discharge line. Each elbows and fittings must be considered as 1 feet of head.

The float switch of your pump has been pre-set at the factory and does not need any adjustment.

Never run the pump dry. Damage to the seal may occur. Fill pump pit or sump basin with water before turning on the power.

STEP 2 Assuming that you have a sump pit located in your basement floor... Your sump pit must be constructed from concrete, brick, tile or more recently a sump basin made from plastic and/or fiberglass. The minimum size of your sump pit must be 18" in diameter and no less than 25" deep. When pit is ready, proceed to next step.

SUMP PUMP APPLICATION

SEE DIAGRAM ON PAGE 5

STEP 3 At this step, you have the opportunity to install a 1 1/2" or a 1 1/4" discharge. We recommend a 1 1/2" ABS/DWV discharge. Install a check valve (350362 in-line 1 1/2" or 350353 1 1/4" MNPT inlet and 1 1/4" or 1 1/2" outlet) over discharge pipe of your pump and secure it with stainless steel clamps or glued nipple for ABS/DWV pipe. This check valve will allow easy access to pump, should service be required.

STEP 4 Install and position your submersible sump pump in the centre of your sump pit or basin and ensure that there is clearance to allow the vertical float switch a free working area without obstructions (pipe, pit's wall, power cord). The float cord length is factory set and should not need adjustment. If adjustment is required, the switch cord can be shorted or lengthed.

STEP 5 Install your discharge pipe from check valve to the point of discharge or drain. For installation over 50 feet of horizontal position discharge pipe, use a 2" pipe to reduce friction loss.

STEP 6 The vertical switch provided with your pump is supplied with a serial electrical male plug. Fix the power cord of the pump into the piggy-back receptacle of the switch and plug this one into electrical grounded outlet. We recommend that a licensed electrician be employed to do wiring. Permanently ground the motor in accordance to the electrical codes for your area. Do not use an extension cord to connect your pump to the power source. From your distribution panel to the receptacle, we recommend a wire gauge not smaller than 14 gauge. Use tape or tie wrap to fix power cords to discharge pipe.

STEP 7 Fill the sump pit or basin with water to test the operation of your submersible sump pump. The motor should start when the water level reaches approximately 3" over your pump. Allow the pump to go through several "on-off" cycle to assure satisfactory operation. If needed, see trouble shooting guide in this manual.

STEP 8 Review your installation with typical diagram. Check all connections for leaks.

MAINTENANCE

Unplug the switch and pump motor power cord. Remove the pump from pit or basin. Remove trash accumulation and dirt from the pump and float switch. Be sure the float switch operates freely after cleaning. If tar or paint has been received in the pit or basin, use kerosene to remove residue from float switch or pump. **Do not use strong paint solvents.**

Remove the screws that hold the strainer or the base to the bottom of the pump body. Pry the base off the pump body carefully. Clean the impeller and volute passage way from any debris which may have become in contact with these parts. Again, If tar or paint has entered pump, clean with kerosene. **Do not use strong paint solvents.** Be sure impeller turns freely after cleaning.

Check and clean away any debris which may be clogging the suction inlet, pump discharge, check valve and discharge line.

Replace screws and return sump pump to sump pit or basin and reconnect to piping.

SUMP PUMP APPLICATION

STEP 3

Determine your choice of discharge pipe size and check valve

STEP 2

Sump pit 18" diameter X 25" depth

STEP 7

Fill the basin and test the operation

STEP 8

Review and check connections for leaks

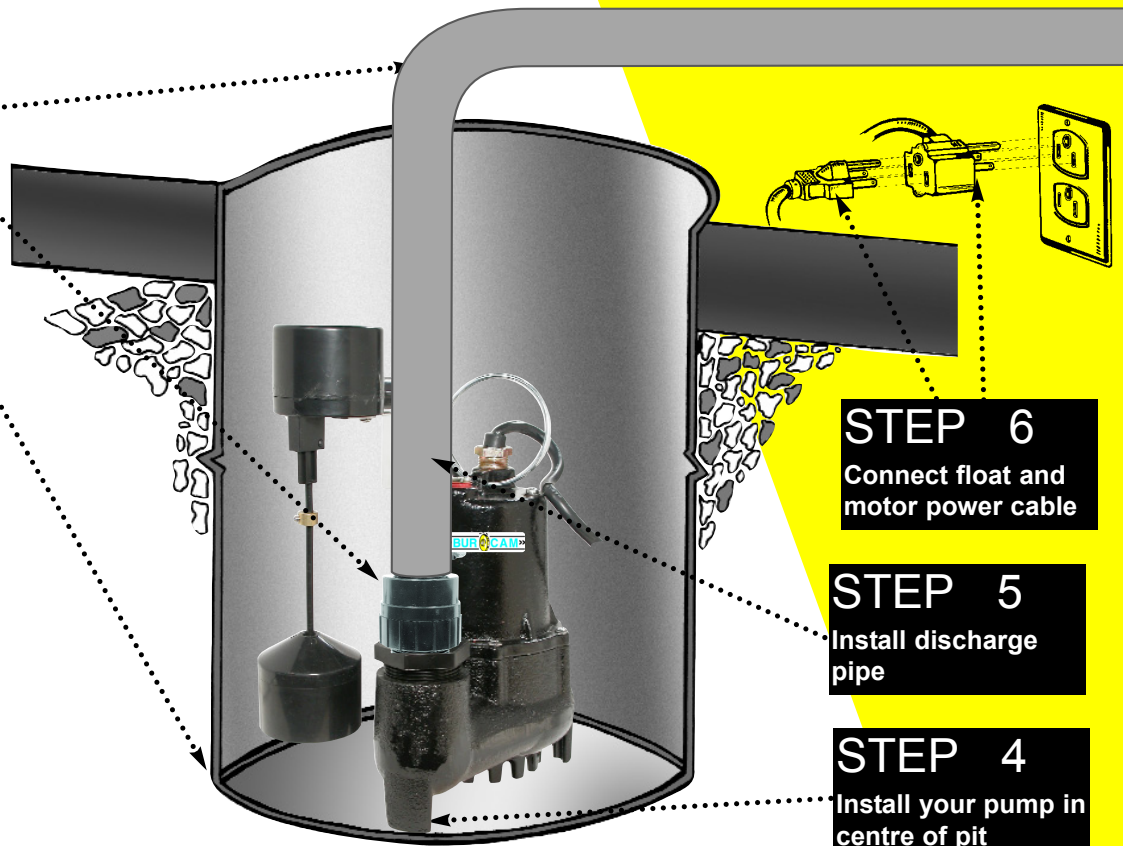

STEP 6

Connect float and motor power cable

STEP 5

Install discharge pipe

STEP 4

Install your pump in centre of pit

REPAIR PARTS

REF.	PART	DESCRIPTION
1	310412	Handle
2	300450	Bearing
3	310414	Top cover screws
4	310415	Motor casing
5	310416	Rotor & shaft
6	310418	Seal cover
7	350311	Oil seal
8	310420	Mechanical seal
9	310421	Impeller
10	310422	Pump casing
11	310424	O-Ring
12	310423	Pump body screws (6)
13	310425	Stator assembly
14	310426	Packing
15	310427	Cable screws
16	310428	Power cable
17	450447	Vertical float switch
18	450402	Screws (4)
19	310411	Switch braket

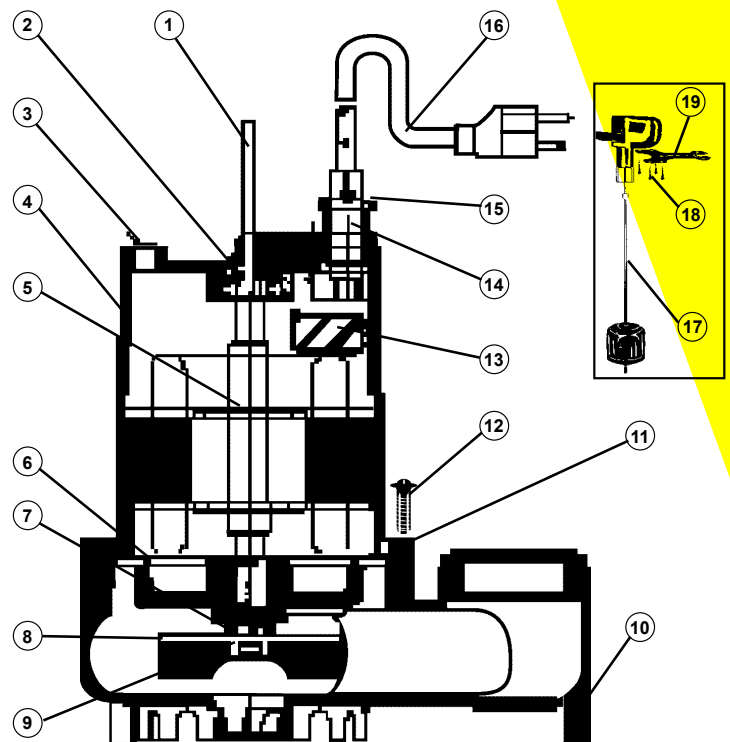

Repair parts may be ordered from your authorized point of sale or from
BUR-CAM PUMPS

TROUBLE SHOOTING GUIDE CHECKLIST

NEVER MAKE ADJUSTMENTS TO ANY ELECTRICAL APPLIANCE OR PRODUCT WITH THE POWER CONNECTED. DON'T JUST UNSCREW THE FUSE OR TRIP THE BREAKER, REMOVE THE POWER FROM THE RECEPTACLE.

TROUBLE	PROBABLE CAUSE	ACTION
Motor does not run.	Switch is off position Blown fuse Tripped breaker Plug disconnected Corroded plug Low water level Thermal overcharge Defective switch/float Defective motor Improper float position	Turn switch to on position Replace Reset Re-install Clean prongs Add water and verify Cool the motor Replace Replace/repair Check movement
Pump does not deliver to full capacity.	Jammed impeller Plugged check valve Blocked suction/inlet Discharge leak Blocked line/pipe Worn impeller Defective motor	Clean Clean/replace Check for debris in pit and clean Repair Check for debris or ice Repair/replace Replace
Pump does not shut off.	Defective switch Float obstruction Blocked suction/inlet	Replace Adjust/check Check for debris in pit and clean

TO THE END CONSUMER

If you have any problems with the product, before advising the store, where you've purchased the pump, please contact us at 514 337-4415, and ask for our sales department, and they will be pleased to help you with any questions you might have, concerning your installation.