

"QUALITY PUMPS SINCE 1939"

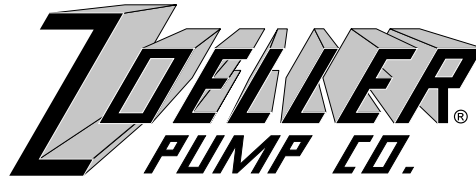

FM1139  
0608  
Supersedes  
1205

Product information presented here reflects conditions at time of publication. Consult factory regarding discrepancies or inconsistencies.

MAIL TO: P.O. BOX 16347 • Louisville, KY 40256-0347  
SHIP TO: 3649 Cane Run Road • Louisville, KY 40211-1961  
(502) 778-2731 • 1 (800) 928-PUMP • FAX (502) 774-3624

visit our web site:  
[www.zoeller.com](http://www.zoeller.com)

# MODEL 510

## "THE BASEMENT SENTRY® II"

### 12 VOLT DC Backup PUMP

#### PREINSTALLATION CHECKLIST

1. **Inspect your pump.** Occasionally, products are damaged during shipment. If the unit or any of the parts are damaged, contact your dealer before using.
2. **Read all the installation instructions** regarding installing and start up. Retain for future reference.



- |   |   |
|---|---|
| <ol style="list-style-type: none"> <li>1. <b>Testing for Ground.</b> As a safety measure each electrical outlet should be checked for ground using an Underwriters Laboratory listed circuit analyzer, which will indicate if the power, neutral and ground wires are correctly connected to your outlet. If they are not, call a qualified licensed electrician.</li> <li>2. <b>For your protection always disconnect the power supply</b> from its power source before handling the components of your DC backup pump or the primary pump.</li> <li>3. Installation and checking of electrical circuits and hardware should be performed by a qualified, licensed electrician.</li> </ol> | <ol style="list-style-type: none"> <li>4. All electrical and safety codes must be followed in addition to the National Electrical Code and all applicable local codes.</li> <li>5.  It is the owner's responsibility to check the battery and battery connection <b>at least once a month</b>. Batteries contain acid and caution must be taken when handling.</li> <li>6. Risk of electric shock - These pumps have not been investigated for use in swimming pool areas.</li> <li>7. According to the state of California (Prop 65), this product contains chemicals known to the state of California to cause cancer and birth defects or other reproductive harm.</li> </ol> |
|---|---|



- |   |  |
|---|--|
| <ol style="list-style-type: none"> <li>1. <b>Make sure there is a properly grounded 115V receptacle available.</b> Do not use primary pump circuit. The location must be within 6' of the control box and battery. The power supply for your DC control system plugs directly into the 115V outlet. <b>DO NOT USE AN EXTENSION CORD.</b></li> <li>2. <b>Make sure the 115V electrical supply circuit is equipped with fuses or circuit breakers of proper capacity.</b></li> <li>3. DC emergency pumps are designed for handling clear water. Do not use in septic tanks to pump effluent or sewage pits to pump sewage.</li> <li>4. Repair and service of your DC backup system should be performed by an authorized service station.</li> <li>5. The installation of DC automatic backup pumps requires the use of a variable level float switch for</li> </ol> | <p>operation. It is the responsibility of the installing party, to ensure that the <u>tethered</u> float switch will not hang up on the pump apparatus or pit peculiarities and is secured so the pump will turn "on" and "off". It is recommended that the pit be 18" in diameter or larger to accommodate both a primary and a DC backup pump.</p> <div style="border: 1px solid black; padding: 5px; margin-top: 10px;"> <p><b>CAUTION</b> Turbulence caused by high velocity incoming water can cause the DC pump to airlock. If this condition exists, the incoming water must be baffled to avoid excessive turbulence.</p> </div> |
|---|--|

REFER TO WARRANTY ON PAGE 2.

## LIMITED WARRANTY

Manufacturer warrants, to the purchaser and subsequent owner during the warranty period, every new product to be free from defects in material and workmanship under normal use and service, when properly used and maintained, for a period of one year from date of purchase by the end user, or 18 months from date of original manufacture of the product, whichever comes first. Parts that fail within the warranty period, one year from date of purchase by the end user, or 18 months from the date of original manufacture of the product, whichever comes first, that inspections determine to be defective in material or workmanship, will be repaired, replaced or remanufactured at Manufacturer's option, provided however, that by so doing we will not be obligated to replace an entire assembly, the entire mechanism or the complete unit. No allowance will be made for shipping charges, damages, labor or other charges that may occur due to product failure, repair or replacement.

This warranty does not apply to and there shall be no warranty for any material or product that has been disassembled without prior approval of Manufacturer, subjected to misuse, misapplication, neglect, alteration, accident or act of God; that has not been installed, operated or maintained in accordance with Manufacturer's installation instructions; that has been exposed to outside substances including but not limited to the following: sand, gravel, cement, mud, tar, hydrocarbons, hydrocarbon derivatives (oil, gasoline, solvents, etc.), or other abrasive or corrosive substances, wash towels or feminine sanitary products, etc. in all pump-

ing applications. The warranty set out in the paragraph above is in lieu of all other warranties expressed or implied; and we do not authorize any representative or other person to assume for us any other liability in connection with our products.

Contact Manufacturer at, 3649 Cane Run Road, Louisville, Kentucky 40211, Attention: Customer Service Department to obtain any needed repair or replacement of part(s) or additional information pertaining to our warranty.

**MANUFACTURER EXPRESSLY DISCLAIMS LIABILITY FOR SPECIAL, CONSEQUENTIAL OR INCIDENTAL DAMAGES OR BREACH OF EXPRESSED OR IMPLIED WARRANTY; AND ANY IMPLIED WARRANTY OF FITNESS FOR A PARTICULAR PURPOSE AND OF MERCHANTABILITY SHALL BE LIMITED TO THE DURATION OF THE EXPRESSED WARRANTY.**

Some states do not allow limitations on the duration of an implied warranty, so the above limitation may not apply to you. Some states do not allow the exclusion or limitation of incidental or consequential damages, so the above limitation or exclusion may not apply to you.

This warranty gives you specific legal rights and you may also have other rights which vary from state to state.

## TROUBLESHOOTING INFORMATION

1. **DC Pump won't run**
  - (a) Check fuse in line from control box center to the battery (see fig. 5) If fuse is blown, replace.
  - (b) Check for proper connections.
  - (c) Check all wire terminal points. Clean if required.
  - (d) Check for low battery. Service battery if required.
2. **Pump runs but pumps very little or no water.**
  - (a) Check for weak battery. Weak battery slow pulse alarm will sound and "yellow" light will blink. Battery will recharge if "Red" power "on" light indicates power has been restored and the float switch is in the off position.
  - (b) If immediate usage is required, remove and replace dead battery with a full recharged battery or place an additional battery in parallel.
  - (c) Due to varying conditions, the pump may continue to run on a weak battery without sufficient power to remove water before the low battery alarm is activated. Pump will stop running when low battery alarm is activated.
  - (d)  Weak batteries can be recharged but may not store sufficient energy for full service. A weak recharged battery can only be detected by reduced pumping time or by checking each cell with a hydrometer. If your emergency pump system is used frequently, the battery should be checked by a qualified battery dealer.
3. **Pump cycles too frequently.**
  - (a) Check tether length on variable level float switch.
  - (b) Lengthen tether as required. 4" recommended for standard installations.
4. **Float switch in "on" position. Pump won't run.**
  - (a) Remove pump. Check for obstruction in pump preventing impeller from rotating.
5. **Pump runs, but pumps water intermittently.**
  - (a) Pump is air locking. Check flow of water incoming to sump. If water is entering the sump at a high velocity creating a turbulent condition, a mixture of air and water may cause a complete or partial air lock and reduce or stop the flow of water in the discharge pipe.
  - (b) Baffle the incoming stream of water to reduce turbulence. Diverting water stream against wall of basin usually corrects an air lock problem.
6. **Water level high, pump startup delayed.**
  - (a) Battery is weak, if battery terminal voltage has dropped to 10.5 volts, the control box automatically shuts off the system for 10 minutes and activates the low battery fast pulse alarm. If main power supply is off, a good quality battery may recover without recharging if the float is in the "off" position, and allow some additional pumping time. If main power supply is "on", the primary pump will lower the water level and the battery will begin recharging. The battery is low if battery terminal voltage drops to 8.5 volts. The control box automatically shuts off the system and activates a fast pulse alarm. The system can not be restarted until power is restored and the battery recharged.
  - (b) If power has been restored and water in sump remains high, check primary pump. Service if required.
  - (c) A completely drained battery may require 18 hours for a full charge.
7. **Alarm sounds during battery recharge cycle.**
  - (a) Push alarm reset (max. 3 times). If condition persists, replace battery.

## DESCRIPTION

The DC emergency pump is designed as a backup to your primary sump pump during unexpected power outages or primary pump failure. The DC pump, control box and all the parts required for installation are included except the batteries which are supplied by the user. The system is designed for installation in sumps with minimum of 18" diameter and 24" deep.

## CHECKLIST

Model <u>510</u> includes:	Part Number
1. DC backup pump with removable clean out screen.....	007777
2. Plastic battery box with safety closure strap .....	005702
3. DC control box (battery charger included).....	007776
4. 1½" X 5" long PVC pipe nipple.....	005639
5. Two check valves.....	005636
6. Two reducer hose couplings and clamps .....	30-0188
7. One - 1½" PVC pipe tee.....	005645
8. One - 1½" 90 degree PVC pipe elbow .....	005644
9. One - 1¼ x 1¼ street elbow, male x female slip.....	008731
10. Pump mounting kit, includes brkt., SS worm drive clamp, two #10-24 screws and washers.....	007798
11. Cable Tie .....	005868
12. "On" - "Off" Float Switch.....	007797
13. Anchors, wall .....	009691
14. Bracket, control mounting .....	007779

## BATTERY SELECTION

The DC emergency pump system requires good quality, 12 volt batteries to obtain maximum pumping time during a power outage. Deep-cycle, 12 volt, 130 amp-hour marine batteries are recommended and will provide approximately 7½ hours of continuous pumping time in a sump pump installation with 8' of head pressure. In most installations the pump runs intermittently and the battery life is extended accordingly. Batteries with top terminals are recommended for ease of installation. Pumping time can also be extended by using additional batteries in parallel. Each additional battery increases continuous run time by approximately 7½ hours. These batteries contain acid and proper precaution must be taken when handling. Maximum battery size 12½" Length x 7" Width x 8" Height.

## PERFORMANCE

The DC pump performance tested with fully charged marine battery.

Discharge Feet of head	5	10	15	19.9
Flow Gal. per min.	33.8	21.6	10.6	Shut-off Head

The DC controller box is designed with a 10 amp battery charger for maintaining the battery in a ready state and for recharging the battery after use when AC power is restored. Time for recharge depends upon the amount of power consumed by the pumping cycle during the AC power interruption. The pump may go back to the ready run position in a very short period of time, one hour or less. A completely drained battery may require 18 hours for total recharge. If more than one battery is used, the time for recharge increases proportionately for each additional battery.

## INSTALLATION

1. Remove all parts from shipping carton and make sure all parts are included. Refer to checklist on page 2.
2. Select location for battery and control box. Control box must be within 6' of a 115V wall outlet and within 6' of pump and basin.
3. If primary pump is installed, disconnect power. If the primary pump is a column pump with adjustable float, check the "on" point and adjust to approximately 7½" from bottom of pump (see fig. 2). Mark discharge pipe 8-3/8" from the "on" point of the primary pump (see Fig. 1 & 2).
4. If existing discharge pipe is metal or flexible tubing, replace with 1½" rigid PVC sch. 40 pipe. If replacing a metal pipe with PVC, use a male adapter for connecting pipe to primary pump outlet.
5. Remove the discharge pipe and cut off at the mark determined in step 3. Remove an additional 7-3/16" from the upper portion of the discharge pipe for installing the pipe loop for the DC pump. (See Fig. 1 & 2).
6. Remove screen from bottom of DC pump by pushing two red lock tabs inward and pulling screen free from pump. Bolt the mounting bracket (item 10, fig. 3) to the bottom of the pump screen. Use #10-24 screws, washers and nuts provided. Make sure the bracket is 90° to the pump discharge. Snap screen and bracket onto pump. (See figs. 1 and 2).
7. Screw the discharge pipe into the primary pump outlet. Tighten with strap wrench. Install the DC pump onto the discharge pipe by using the S.S. worm drive clamp provided in the mounting kit (item 10, fig 3). The bottom of the DC pump should be located 5-3/8" from the end of the discharge pipe. (See fig. 1 and 2).
8. Assemble the pipe loop (items 4 thru 9 as shown in fig. 3). Use a commercial grade of PVC cleaner and solvent cement (not furnished with kit) on all the socket joints. Tighten all pipe clamps, except lower clamps on rubber couplings, (items 6C fig. 3), used for connecting the pipe loop to the discharge pipe and pump (see figs. 1 and 2).
9. Install the pipe loop assembly, using the rubber couplings and clamps (items 6C fig. 3). Tighten all clamps.
10. Install the float switch assembly on the lower leg of the discharge outlet tee using the clamp provided (see fig. 1 and 2). Set tether length to 4". Position pumps in the sump and move float up and down, making sure of free movement without interference from any obstructions inside the sump or lid. Very shallow sumps may require some adjustment to avoid overflowing or backing up of water into the sump inlet. The float switch can be lowered on the discharge pipe or the 4" tether length can be reduced to 3½" min.
11. If the old primary pump discharge piping is being replaced with PVC piping, duplicate the old pipe dimensions and use the existing drainage connection. If the primary pump and backup pump is a new installation the drainage connection must be determined and the discharge pipes fitted accordingly. Solvent weld the upper portion of the discharge pipe into the PVC tee outlet (see fig. 1 and 2). Connect the discharge pipe into the drainage connection. The pipe must be supported from above to assure proper alignment of the DC pump loop.
12. Install DC control box in suitable location by using the wall bracket and anchors provided. (See fig. 5). Place fully charged battery in plastic battery box.
13. With the AC power REMOVED, connect the chargers' positive output lead to the positive post of the battery. Connect the chargers' negative output lead to the negative post of the battery. Install the fuse into the yellow "in-line" fuse holder. At this point, the chargers' "correct connection announcement" should be observed. The "correct connection announcement" is an audible "beep" and several LED flashes. If the "correct connection announcement" does not occur, it is possibly due to power fluctuations when the fuse was installed. To alleviate this condition, disconnect the fuse for approximately 15 seconds and then **CAREFULLY** reinstall the fuse into the fuse holder. The "correct connection announcement" should be observed.
14. Apply grease to battery terminals to help prevent corrosion.
15. Close battery box and secure cover with lock strap supplied. (Lock not furnished).
16. Connect the plugs from the pump and the float switch to the control box terminals. Refer to fig. 5 and 6 for location of each terminal plug.
17. Plug the control power cord into 115V wall outlet. The primary sump pump and the control box should be on separate circuits.
18. **Reconnect power to primary sump pump.**

## INITIAL STARTUP AND OPERATION

1. Test the installation for leaks by running water into the sump allowing for normal operation of the primary pump.
2. Check DC pump backup control system as follows. Refer to fig. 6.
  - (a) Continuous "Red" light indicates power supply is "on".
  - (b) "Yellow"/"Green" light is the battery indicator light. A continuous yellow glow indicates the battery is being charged. This turns to "Green" when battery is fully charged. Upon full charge, it is normal for this light to alternate between Yellow and Green.
  - (c) Reset lower toggle and lift float switch. DC - pump will run, "Yellow" pump run indicator light will flash and continuous alarm will sound. Release float switch immediately after pump has started running. Pump is running dry during initial check out for several seconds. **CAUTION** Continuous dry running may cause overheating and damage to the pump seals.
  - (d) Upon release of float switch, pump will shut "off", alarm will shut "off", "Yellow" pump run indicator light will stay "on". Turn off the "Yellow" pump light by pushing the toggle switch down for less than 3 seconds. The alarm will beep twice indicating the system has been reset. The "Yellow" light indicates the emergency pump has operated to relieve a flooded sump and should be reset with the toggle switch after the emergency situation has been cleared up and water level in the sump has dropped below the "off" point.
  - (e) Alarm "on/off" switch is for the convenience of the owner. If the alarm becomes an annoyance when the emergency pump is running it can be silenced by pushing the toggle switch up. The yellow pump silence indicator is a reminder light to indicate the alarm is in the "off" position. The "Yellow" pump run indicator light will continue to function and indicate when pump is running or has been running.
  - (f) The control box will activate an alarm signal if the battery is weak. The alarm will sound at a fast rate and will continue until the battery is partially recharged back to an operating level for the pump. The "Red" signal light will blink when the alarm sounds. The alarm will continue at a fast pulse if the battery becomes too weak for normal operating of the pump. The pump will automatically shut off until the battery is recharged. The alarm will sound at slower rate as battery becomes recharged to a usable level for pumping. The red low-battery light will also pulse at a slower rate.
  - (g) If an extended power outage occurs a battery may be drained below the power level required for operation of the pump. If more than seven hours of continuous run time is required. Two or more batteries should be connected in parallel to extend the run time hours.
  - (h) After power is restored your "Basement Sentry®II" control box will automatically charge the batteries back to full power. Several hours of recharge time may be required before pump can be restarted.
3. Complete the final testing of your installation by disconnecting the power to the primary pump and removing the power cord from the wall socket. Run water into the sump until the DC pump is activated by the float switch. Check pump loop and back flow valves for leaks. Check control function as follows:
  - (a) Red power light is "flashing" (power cord is disconnected from the 115V outlet).
  - (b) Yellow pump run indicator light is "on" when float switch rises.
  - (c) Alarm is "on" when float switch rises. (Check alarm "off" switch).
  - (d) Pump shuts "off" when water level and float switch drops.
  - (e) Alarm goes "off" when water level and float switch drops.
  - (f) Yellow pump run indicator light is "on" until reset button has been pushed.
4. Reconnect the power cord and your primary pump to the AC wall outlets. The primary pump should come on and lower the water level in the sump back to the normal operating level and shut off. Both primary and backup system are now ready for use.

# ASSEMBLY WITH SUBMERSIBLE PUMP

ASSEMBLY WITH SUBMERSIBLE PUMP

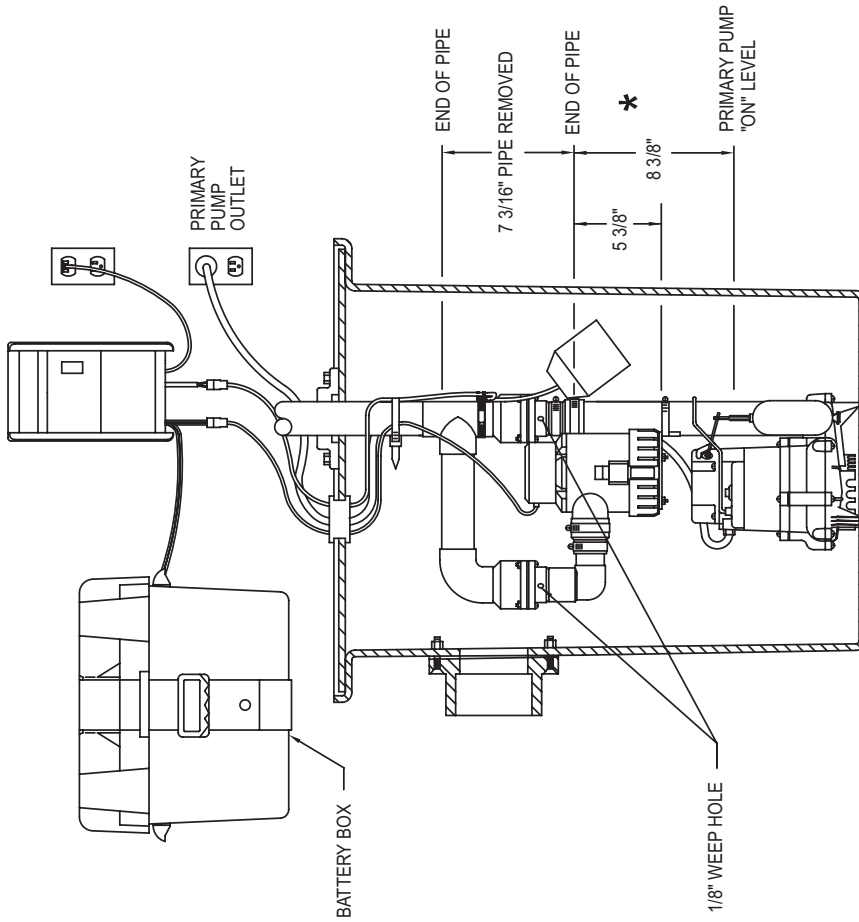

# ASSEMBLY WITH COLUMN PUMP

ASSEMBLY WITH COLUMN PUMP

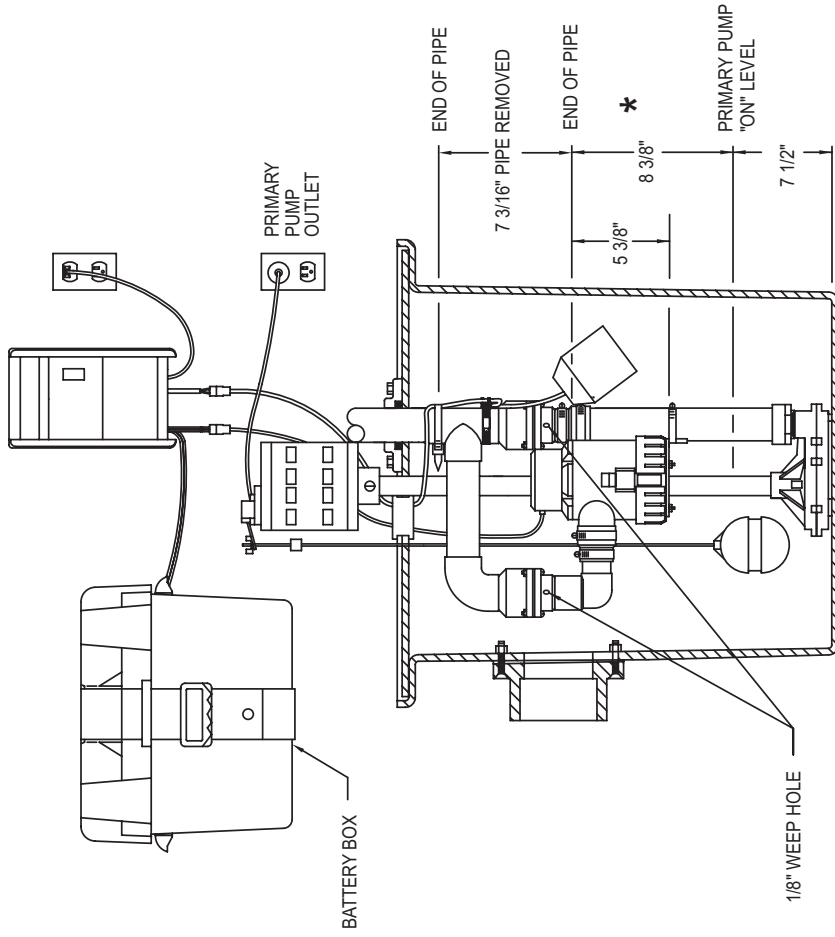

\*The 8 3/8" Dimension can be altered to accommodate small basins with min. depth of 24".

FIGURE 1

FIGURE 2

# FLOAT SWITCH

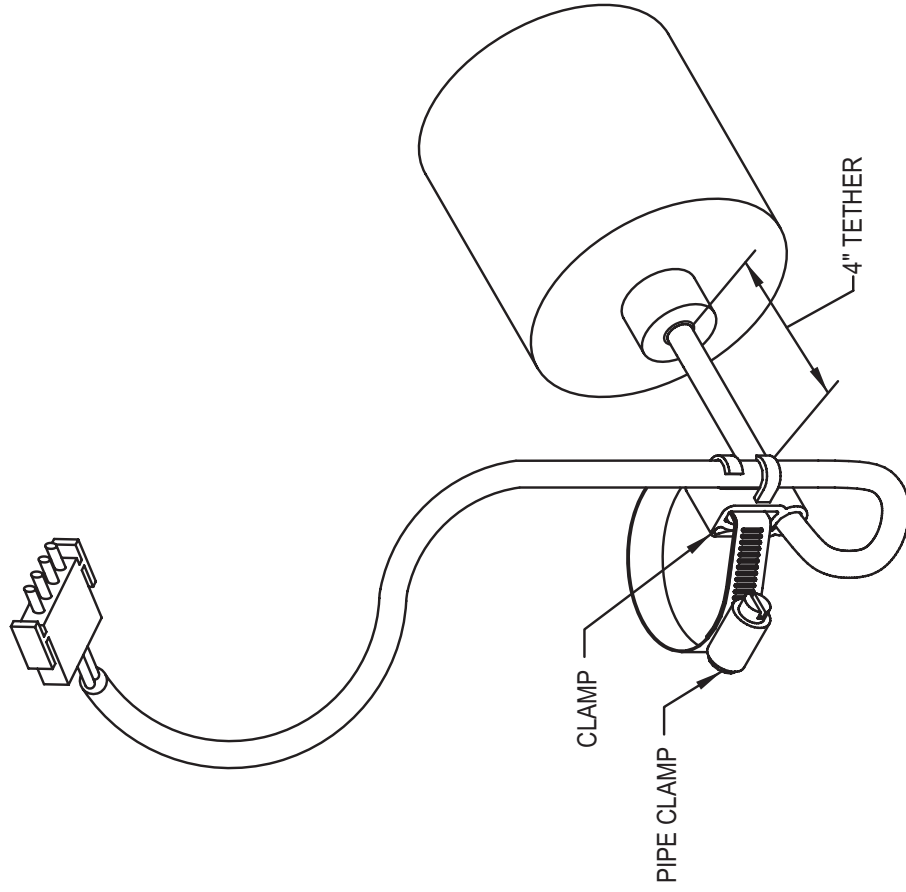

FIGURE 4

SK957

# PUMP LOOP ASSEMBLY

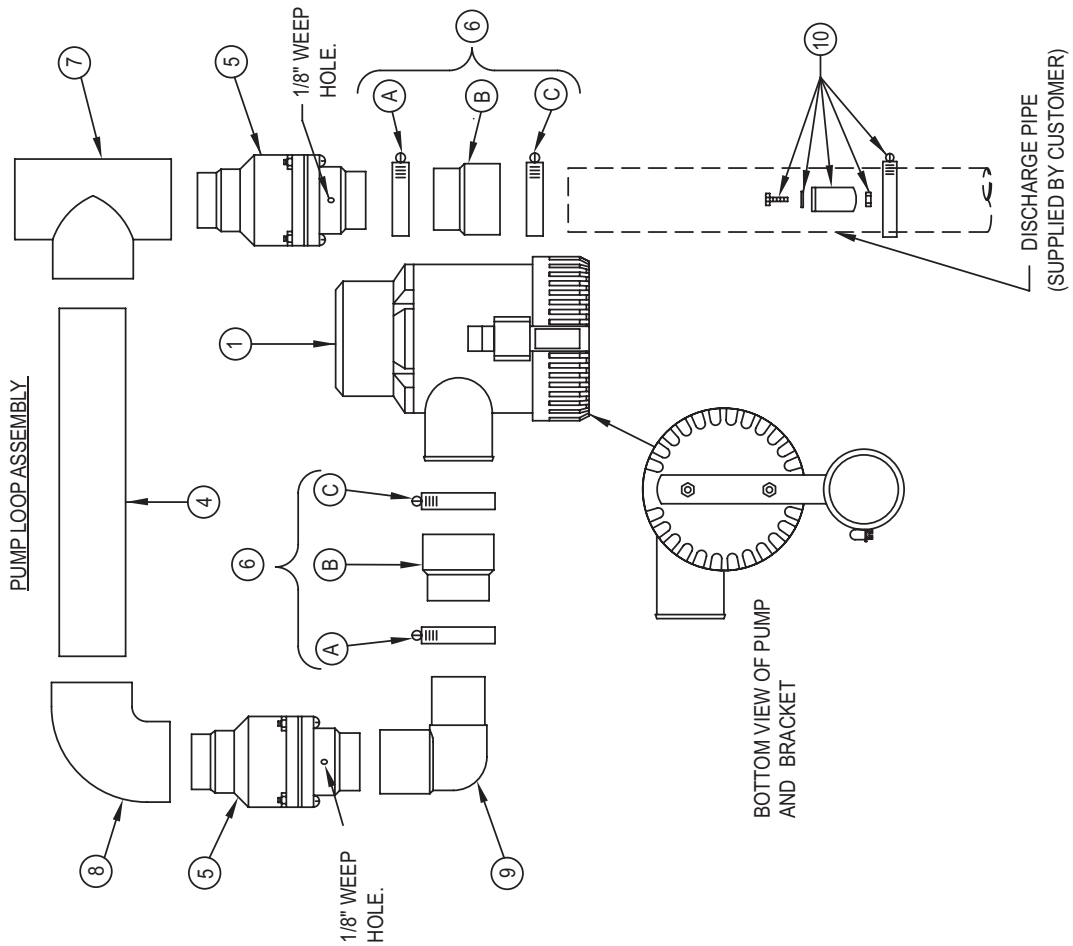

FIGURE 3

SK1220

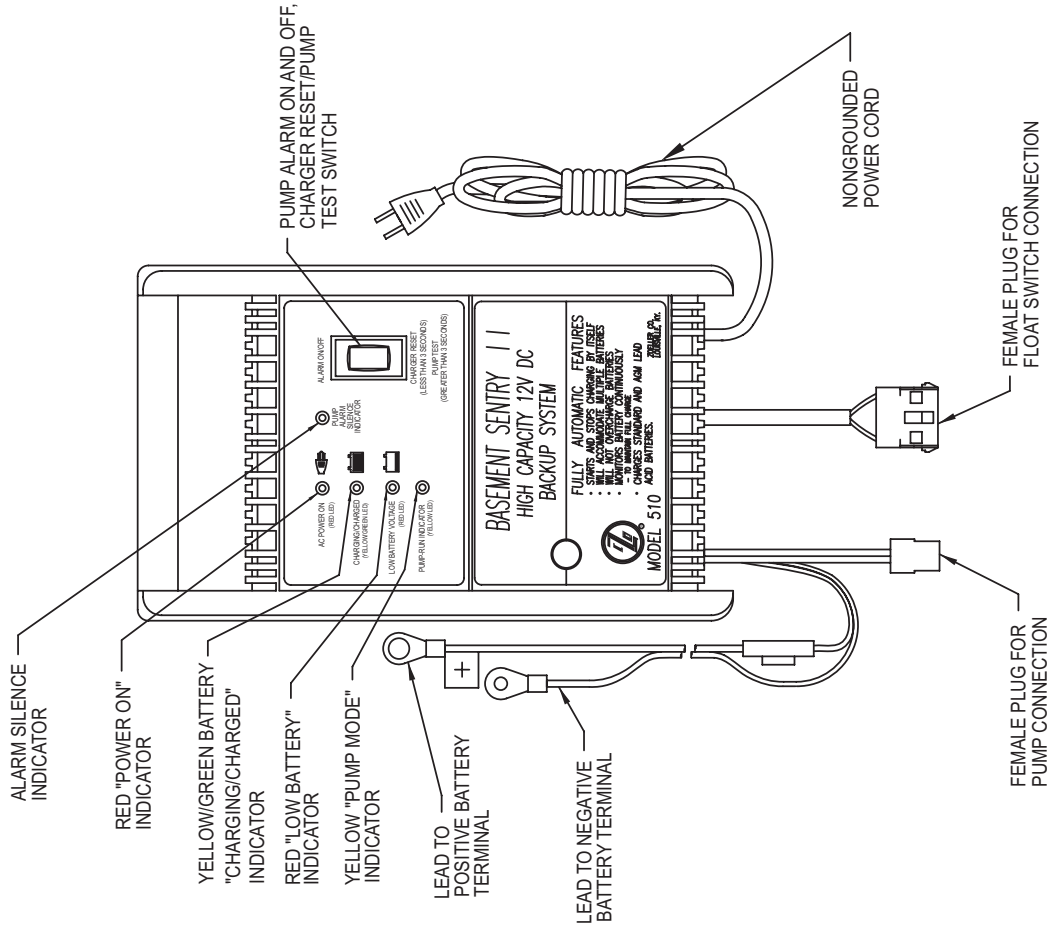

FIGURE 6

SK1221

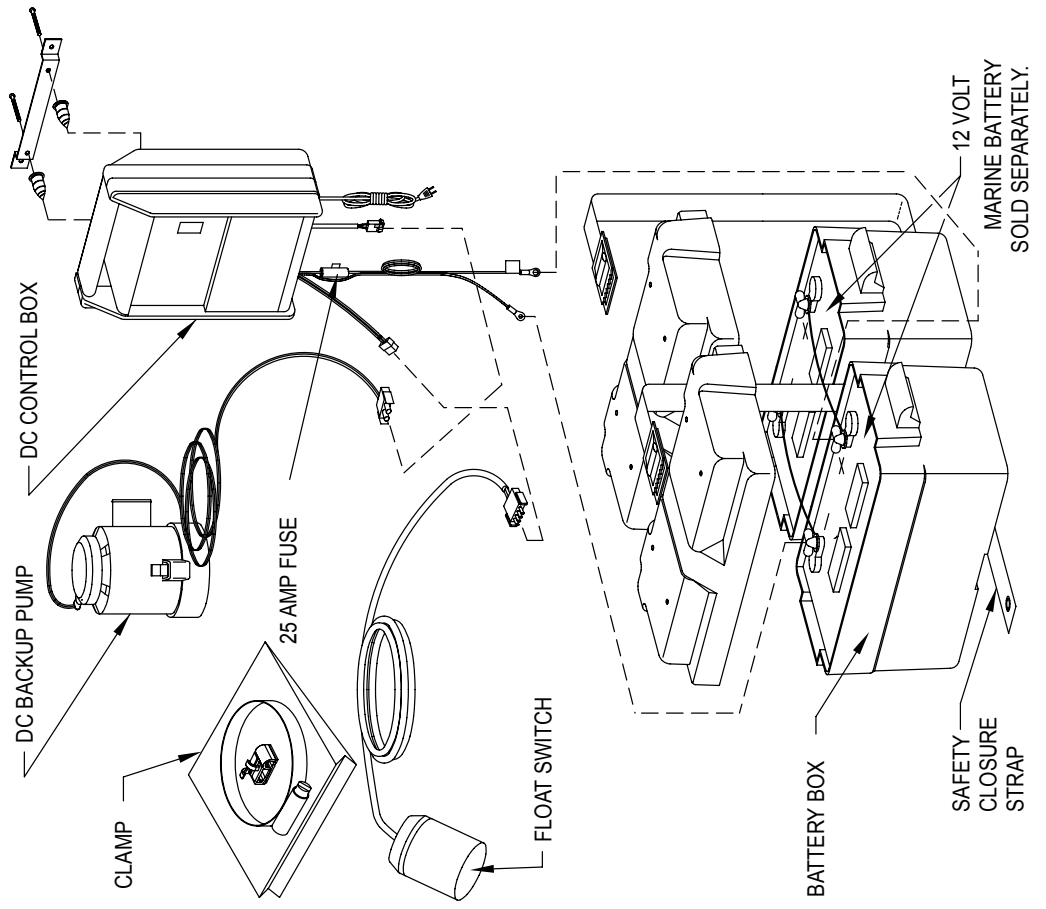

FIGURE 5

SK1226



## MAINTENANCE

1. Check system at least every three months.
  - (a) Red power “on” indicator light should be “on” indicating AC power is connected.
  - (b) Unplug primary pump, and power supply.
  - (c) Press and hold test switch. After 3 second delay pump should operate.
  - (d) Check control box functions. “Yellow” pump run indicator light is turned on and alarm sounds when pump starts. Alarm goes “off” when water level drops to “off” point.
  - (e) “Yellow” pump run indicator light is turned “off” with reset switch.
  - (f) “Yellow” glow light indicates battery is being charged if power is on. “Green” light indicates fully charged battery.
2. Should battery drop below the safe operating level for the pump, the weak or low battery pulse alarm will be activated. If the alarm continues, the condition indicates the battery has not had sufficient time to recover or the battery terminals are dirty. If this condition continues

after power has been restored the battery terminal should be cleaned or the battery replaced.

3. The alarm “off” switch should be reactivated by pushing reset switch when pump is placed back in service so you will be warned the next time the emergency pump is used. If alarm remains in “off” position a yellow reminder light will glow continuously.
4. After test is completed plug power cord in wall outlet. Red light will indicate power on.
5. **Ensure that primary pump is plugged in and operational.**

6.  **WARNING** Battery acid is dangerous. Take proper safety precautions. Do not splash the acid. Add distilled water to battery when necessary per battery manufacturers’ instructions.

## THE AQUANOT BATTERY

Due to the diversity in design and capacity of batteries, Zoeller Company offers a line of batteries specifically tested for use with the “Basement Sentry®” Series Backup system. We offer both a Water/Acid Deep-Cycle Battery which can run the pump continuously for over 7½ hours, and a Maintenance-Free AGM Battery, which will power the pump for over 3½ hours. This time is based on continuous pumping at 8’ of static head. Actual time will vary depending on static head, volume of water entering the pit, and the condition of the battery.

### Follow these recommendations:

- Use a B.C.I. size 27 deep-cycle battery, 175 minute reserve capacity, or larger.
- Do NOT use a “maintenance-free” battery unless it is a Gel-filled or AGM battery.
- Replace your battery every 3 years.
- Do not let corrosion build up on the battery terminals.
- Do not place your battery on a concrete floor where it will discharge faster.
- To check specific gravity, follow the instructions on a hydrometer (not applicable for Gel or AGM batteries).

### PROTECT YOUR WARRANTY:

- With the exception of Gel and AGM batteries, water level in batteries must be checked once a month.

## CARBON MONOXIDE DETECTORS

Whether you have a “Basement Sentry®” Backup Pump System, or a competitive brand, all use batteries that give off gaseous by-products when charging. Some of these by-products can produce a rotten egg odor. Also, some of these by-products can cause a CO detector to falsely activate. In order to help prevent false activation, Zoeller Company recommends moving the battery as far apart from the CO detector as possible or, if necessary, vent the battery to the exterior. Zoeller Company provides the previous statements only as guidelines to help prevent false activation of the CO detector. In no way are they meant to supersede the instructions that accompany the detector nor do they supersede advice from the CO detector manufacturer.

If the audible alarm associated with your CO detector is activated, we recommend the following actions:

- 1) Take immediate action for personal safety as recommended in the CO detector literature.
- 2) Contact the appropriate agency to determine if the CO is being produced by your furnace, water heater, or any other device which uses natural gas.
- 3) If you are certain that no CO is being produced, then a charging battery may be producing gaseous by-products which are causing the CO detector to activate. Contact the manufacturer and ask for recommendations as to what can be done to prevent the alarm activation.