

LIMITED WARRANTY AND LIMITATION OF LIABILITY

This product is warranted to be free from material and/or manufacturing defects for three years from date of purchase. As the sole and exclusive remedy for a breach of this limited warranty, if the product is found to be defective, it will be repaired or replaced with an equivalent product if it is returned to the place of purchase with proof of purchase. Any disassembly, modification, or abuse of this product voids this limited warranty. This product is not designed for pumping flammable or corrosive fluids, and use of this product to pump such materials also voids this limited warranty.

**PROFLO DISCLAIMS ALL OTHER
EXPRESS OR IMPLIED WARRANTIES,
INCLUDING WARRANTIES OF
MERCHANTABILITY OR FITNESS FOR A PARTICULAR PURPOSE.**

IMPORTANT NOTICE: Some commercial and residential insurance policies extend coverage for damages incurred by product failure. In most cases, you will need to have possession of the product to support your claim. In the case where you need to retain possession of the product to support a damage claim you submit to your insurance company, PROFLO will exchange the unit or refund the original price once the claim is settled with the insurer.



OWNER'S MANUAL

INSTALLATION AND OPERATION INSTRUCTIONS FOR PRE-ASSEMBLED PRIMARY & BATTERY BACKUP SUMP PUMP SYSTEM Model: PF92952 & PF92941



Carefully read and understand all of the Warnings and installation instructions in this manual. Failure to follow these instructions could lead to serious bodily injury and/or property damage. Retain these instructions for future reference.

! DANGER Water and electricity can be dangerous if certain precautions are not adhered to. This pump is designed to operate perfectly safe in a water environment; however, improper use and installation can result in personal harm from electrical shock. Please pay attention to the following warnings.

! WARNING Never touch any electrical device, including this pump and charger, when it is touching water, in water, or even in a moist environment. Always unplug (disconnect the electricity) when working on or installing the unit.

! WARNING Always use a grounded outlet. A three-prong mating type receptacle is required for safe use. This should be in accordance with the National Electric Code and any additional codes or laws required by your local government.

! WARNING RISK OF ELECTRICAL SHOCK. Do not plug in or unplug the AC transformer while standing on a wet floor. If basement floor is wet, disconnect the power before walking on the floor.

! WARNING Do not use the power cord or discharge hose to carry or handle the pump. Doing so may cause damage to the power cord or discharge hose. Use the carrying handle supplied with the pump.

! WARNING Battery acid is corrosive. Do not spill on skin, clothing, or parts of this system. Wear gloves and eye protection when handling the battery.

! DANGER This pump is designed to pump clear water. Do not use this pump to pump chemicals, flammable liquids, sewage or corrosive liquids. You could injure yourself and the pump will fail. Pumping these types of liquids voids the warranty.

! WARNING It is strongly recommended to use a ground fault interrupt device on any electrical appliance, including this pump, when used in a wet or moist environment as it provides a much safer installation and will greatly reduce possible injury from electrical shock. This is required by many local codes and enforcement agencies.

! NOTICE For best performance, it is recommended to connect the AC transformer power cord directly to a grounded GFCI outlet. The use of extension cords is NOT recommended.

! DANGER Keep all electrical connections away from wet and moist environments. Wet connections can cause electrical shock resulting in personal injury.

REPLACEMENT PARTS

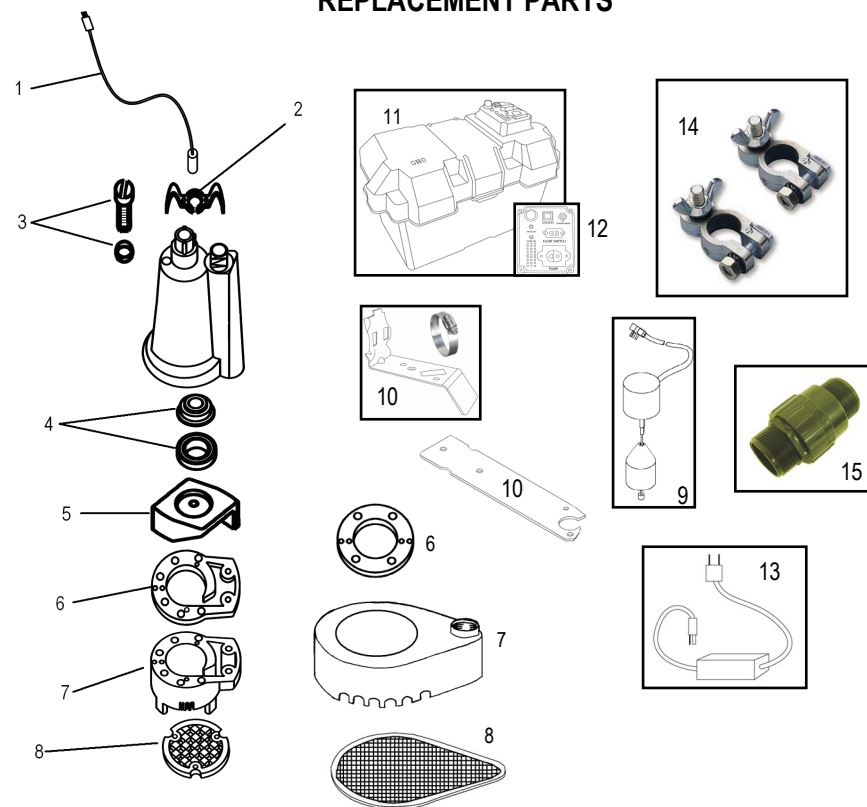

Ref	Description	PART FOR MODEL #		
		92910 Pump	PF92341 Pump	PF92352 Pump
1	Power Cord	99158	n/a	n/a
2	Handle	99051	99053	99053
3	Oil Fill Plug with O-ring	99056	99056	99056
4	Shaft Seal	99057	99057	99057
5	Impeller	99065	99096	99070
6	Gasket	99062	99088	99064
7	Volute/Base	99067	99078	99071
8	Intake Screen	99073	99076	99074
9	Float Switch	92091	92010	92010
10	Vertical Float Switch Bracket	99195	99105	99105
11	Battery Box (Complete Unit)		99464	
12	Control Panel		99465	
13	AC Power Cord		99467	
14	Battery Terminals (+ & -)		99460	
15	Check Valve		99505	

NOTICE Height and/or piping restriction will reduce the pump output performance. See the performance chart below to insure you have the proper pump for your application. Whenever possible use the same size or larger pipe as the pump discharge for optimum performance. Reducing the pipe size will not harm your pump; it will just reduce the output.

PERFORMANCES

Model #	Output in gallons per minute at listed discharge height above pumping level					
	0'	5'	10'	15'	20'	25'
PF92910*	23	22	18	13	8	
PF92341	46	36	30	25	12	1
PF92352	60	56	50	35	15	6

*Performance ratings are based on using a 27M, 12 volt deep cycle marine battery with a 100 Ah rating

SPECIFICATIONS 12 VOLT DC PUMP - MODEL 92010

Motor.....	12 volt DC
Amps.....	13
Battery Requirements.....	12 Volt Deep Cycle Marine
Low Voltage Shut off.....	10 Volts
Solids Handling.....	1/8"
Discharge Size.....	1-1/4" or 1-1/2"
Battery Charger.....	2 amp
Liquid Temperature Range.....	32°-120°F (0°-49°C)

SPECIFICATIONS 120 VOLT PRIMARY PUMP - MODEL 92352

Motor.....	120 Volt AC
Amps.....	7.6 Amps
Solids Handling.....	1/2"
Discharge Size.....	1-1/2"
Liquid Temperature Range.....	32°-120°F (0°-49°C)
Power supply requirements.....	120V, 60 Hz (15 amp)
Motor.....	Continuous Duty, Capacitor Start, Thermally Protected

SPECIFICATIONS 120 VOLT PRIMARY PUMP - MODEL 92341

Motor.....	120 Volt AC
Amps.....	4.1 Amps
Solids Handling.....	3/8"
Discharge Size.....	1-1/2"
Liquid Temperature Range.....	32°-120°F (0°-49°C)
Power supply requirements.....	120V, 60 Hz (15 amp)
Motor.....	Continuous Duty, Capacitor Start, Thermally Protected

BATTERY SELECTION

This system is designed to work with 12 volt, lead-acid deep cycle marine / RV batteries. Either a flooded cell (serviceable or maintenance free) or sealed AGM battery are acceptable. Choose a battery with a minimum 90 amp-hour rating and a 175 minute reserve capacity or larger. Avoid using automobile batteries as these types of batteries are not intended to be charged/discharged for extended periods of time. The Battery case will hold size 24 or 27 batteries.

During prolonged periods of power failure or in an emergency, your automobile battery may be used. Make sure to replace the deep cycle battery as soon as possible as the automobile battery will be quickly ruined by the continuous charge/discharge cycles.

CARBON MONOXIDE (CO) DETECTORS

All backup pump systems that use lead acid batteries, regardless of brand, give off gaseous by-products when the battery is charging. Some of these by-products can cause a carbon monoxide (CO) detector to give a false alarm. When installing this system, position the battery as far away from the CO detector as possible. **DO NOT** move or remove CO detectors from their original location. Always follow the instructions that accompany your CO detector.

If your CO detector alarm sounds, take the following actions.

1. Take immediate action for personal safety as outlined in the CO detector manual.
2. Contact the appropriate utility agency to determine if the CO is coming from your furnace, water heater or other appliance that uses natural gas

If it's determined that a charging battery is causing the CO detector to activate, contact the manufacturer for recommendations on how to alleviate the problem.

USE AND INSTALLATION

! WARNING ALWAYS DISCONNECT THE POWER SOURCE BEFORE ATTEMPTING TO INSTALL, SERVICE OR PERFORM MAINTENANCE ON THE PUMP. FAILURE TO DO SO MAY RESULT IN FATAL ELECTRICAL SHOCK.

! NOTICE A qualified electrician must perform all wiring.

INSTALLATION

This PROFLO pump kit is completely assembled. To install, simply place the pump assembly in the in the bottom of your basin and connect to your new or existing discharge pipe. The pump should be placed on a solid foundation. Do not place the pump directly on the ground or sandy or rocky surfaces. Sand and small stones may clog or cause damage to your pump.

Make sure the float switches will operate freely without coming in contact with the sides of the sump basin. Contact with the side of the sump basin may cause the switch to malfunction. See figure below.

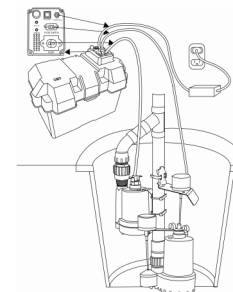

ELECTRICAL CONNECTIONS

1. If necessary, attach the provided battery terminals to the battery. (Many deep cycle marine batteries come with a threaded post terminal built in.) **NOTE:** The provided battery terminals are labeled (+) positive and (-) negative. Make sure the terminals are connected to the proper terminal on the battery. Place the battery in the battery box.
2. Connect the battery lead wires from the control panel to the corresponding terminals on the battery. Connect the red (+) positive lead to the positive battery terminal and tighten the wing nut. Connect the black (-) negative lead to the negative battery terminal and tighten the wing nut. Secure the battery box cover to the lower case.
3. Next connect the pump power cord, the float switch and the AC adapter to the corresponding terminals on the control panel. Make sure they are fully seated in the terminal sockets.
4. Plug the primary pump float switch plug into a grounded outlet. Next plug the primary pump plug into the piggy back plug of the float switch.
5. Plug the AC adapter into the wall outlet and turn the power back on.
6. Test both pumps by lifting and holding the float switches in the "UP" position. The alarm will sound and the "PUMP ON" light on the control panel will illuminate. The pump should start after lifting the float. If it does not run, check your connections and retry.
7. Test the "MUTE" button when the alarm is sounding. Press once to mute the alarm. The MUTE ON light should illuminate. Press again to re-activate the alarm.

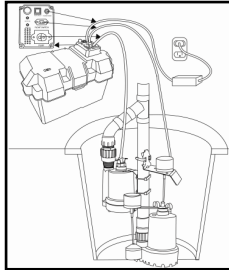
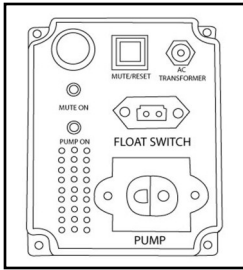

TESTING YOUR INSTALLATION

1. Once your installation and wiring connections are complete, unplug or disconnect the power to the primary pump.
2. Fill the basin using buckets or a hose. Observe the float switches to make sure they are positioned properly when the basin is filling. Fill the basin until the backup float switch activates the alarm. The pump should start and drain the basin.
3. Make any necessary adjustments to the float(s) and/or pumps at this time.

OPERATION

1. When the power fails or when there is a problem with the primary pump, the back-up pump will automatically start. The back up pump will operate for many hours intermittently. During prolonged periods of power outage the pump may stop pumping when the battery voltage drops below 10 volts. When this happens the alarm will sound signaling that the voltage is too low to operate the pump.
2. This unit is equipped with a 2 amp charger. It will charge a discharged battery at a rate of 2 Ah (Amp hours). Once the battery reaches a full charge, the charger will gradually reduce the charge rate. It will also maintain a charged battery by periodically checking the voltage of the battery.
3. The charger is equipped with over charge protection. I will not let the battery become over charged.

12 VOLT DC BACKUP PUMP TROUBLESHOOTING

PROBLEM	POSSIBLE CAUSES	HOW TO CORRECT
Pump won't run.	Loose, corroded or reversed wire connections	Tighten, clean or reconnect if necessary
	Discharged battery	Charge battery
Pump hums but won't run.	Defective battery	Replace battery
	Blown fuse	Replace with 20 amp fuse
	Float switch is stuck	Position float so it moves freely
	Battery is discharged below 10 volts	Fully charge battery
Pump cycles too often	Float switch positioned improperly	Reposition float switch
	Defective or missing check valve	Install or replace check valve
Pump runs but moves little or no water	Low or discharged battery	Fully charge battery
	Obstruction in pipe	Clear obstruction
	Discharge pipe height/length exceeds the capacity of the pump	Check performance section for capacity of this pump
	Defective check valve	Replace Check Valve if necessary

120 VOLT AC PRIMARY PUMP TROUBLESHOOTING

PROBLEM	POSSIBLE CAUSES	HOW TO CORRECT
If the pump does not start or run	Pump is not plugged in, switch or breaker is off	Plug pump in or turn on switch/breaker
	Check for blown fuses or tripped circuit breakers or tripped GFCI outlets	Replace fuse, reset breaker, reset GFCI outlet
	Float switch is defective	Check and replace if necessary
	Motor thermal protector tripped	Allow pump to cool. Pump will reset
	Float switch is stuck or obstructed	Remove obstruction or position pump so it will not become stuck
The pump starts and stops too often	Backflow of water from discharge hose/pipe	Install or replace check valve
	Float switch is defective	Replace float switch
If the pump runs but moves little or no water	Clogged intake screen	Clean or replace screen
	Clogged discharge hose/pipe	Remove clog
	Frozen discharge hose/pipe	Allow hose/pipe to thaw
	Pump is air locked	Clean out airlock hole with a paper clip or pipe cleaner
	Low line voltage	Check wire size and increase if necessary
	Check valve is stuck in the closed position	Inspect, repair or replace if necessary
	Check valve is installed backwards	Make sure check valve is installed in the correct direction of flow
Pump does not shut off	Worn, damaged or clogged pump parts	Inspect for wear, damage or clog and clean or replace if necessary
	Discharge head exceeds pump capacity	If pumping height is over 25', the pump will not move water. See performance chart
Pump does not shut off	Float switch is obstructed or stuck	Remove obstruction
	Defective Float Switch	Replace switch