

# PumpGuard Plus

Pump alternator with high water alarm  
Model #20102

## INSTALLATION INSTRUCTIONS

Dated: 05/15/07

Supersedes: 04/12/07

Document No.: PGP-OM

Page 1 of 5

### SAFETY PRECAUTIONS



**WARNING:** To prevent fire or shock hazard, do not expose this product to rain or moisture. This product has a NEMA-1 rated enclosure for use in an indoor environment. Never spill liquid of any kind on the product.



**CAUTION:** Risk of Electric Shock. To reduce risk of electric shock, do not remove cover. No user serviceable parts inside. Refer servicing to qualified service personnel.



**CAUTION:** To prevent electric shock, insure product is connected to a grounded outlet. The electrical outlet should be properly wired to a dedicated 15A circuit breaker. Proper short-circuit and overload protection must be provided at the distribution panel. Install in accordance with all local and national electrical codes.



**WARNING:** Follow proper installation procedures. Recommended mounting is above floor level. For best performance, do not use electrical extension cords.

### INTRODUCTION

#### Advantages of the PumpGuard Plus

- Added Protection; if one pump fails the PumpGuard Plus will alternate to the other pump while sounding an alarm and keep your pump in operation until repairs can be made.
- Remote Alarm Contacts, can be tied into your home security system or an automatic dialer to alert you to trouble when you are away from home.
- Quick and easy set up, just mount the unit on the wall, plug in your pump cords and high water alarm, and you are set to go!
- PumpGuard Plus can be plugged directly into the optional Sumpro Battery Backup System ensuring system operation during power outages.



*PumpGuard Plus includes PumpGuard Plus control box & high water alarm*

Patent No. 5,449,274 

### TABLE OF CONTENTS

General Operation .....	1
Installation .....	2
Testing .....	3
Troubleshooting .....	4
Accessories .....	5
Specifications .....	5

### GENERAL OPERATION

**Note:** Please follow installation instructions before applying power.

The PumpGuard Plus is a pump alternator with high water alarm for use with two sump or sewage pumps.

Upon first energizing the PumpGuard Plus the Power On indicator will illuminate and the controller will be ready to alternate the pumps starting with Pump 1. Each time a pump is activated an indicator on the front of the controller will illuminate informing you of which pump is running.

The PumpGuard Plus will allow each pump to operate normally, but will allow only one pump to run at each pump down cycle. After the first cycle, the PumpGuard Plus then switches to the next pump alternating cycles to increase pump life. If one pump fails to operate due to pump or switch failure, the level within the pit will rise

# PumpGuard Plus

Pump alternator with high water alarm  
Model #20102

## INSTALLATION INSTRUCTIONS

Dated: 05/15/07

Supersedes: 04/12/07

Document No.: PGP-OM

Page 2 of 5

until the High Water Alarm Float is activated. When the High Water Alarm Float is activated, the PumpGuard Plus will switch to the next pump in sequence allowing the pump down cycle to be completed. During a High water situation, in conjunction with the alternation, the PumpGuard Plus will sound an audible alarm, illuminate the Alarm indicator, and change state of the High Water Alarm Remote Contact (see High Water Alarm Remote Contact for more details). After the high water pump down, The PumpGuard Plus will alternate to the next pump in sequence. If the failed pump or switch has not been corrected, the PumpGuard will continue the alarm cycle sequence until the failure is corrected, restoring normal operation. This allows you to take advantage of having two pumps in a single sump for added security and peace of mind.

An additional feature of the PumpGuard Plus is the five minute run timer. If either pump runs for five minutes in one cycle, the PumpGuard Plus will sound a intermittent audible alarm. This alarm is used to alert you in the event of excessive flow into pump pit or the possibility of a faulty pump, switch, check valve or blocked pipe situation.

### INSTALLATION

**Note:** Do not plug in the AC cord until all connections have been completed.



**WARNING:** Verify the electrical outlet is properly wired and grounded as per local and national electrical codes. Verify that the electrical circuit is a dedicated circuit.

Verify proper operation of all pumps and switches before starting installation. Note that the pump switches on/off levels are installed at approximately the same height (see figure 2).

Determine a location that is suitable for the placement of this product near the pump pit.

Securely mount the PumpGuard Plus to the wall using four mounting holes on the enclosure (see figure 1)

Mount the alarm float on the pump discharge pipe and adjust the it so that it will only activate at a level higher than the turn on level of the pumps (See figure 2)

You are now ready to attach the pump, switch and

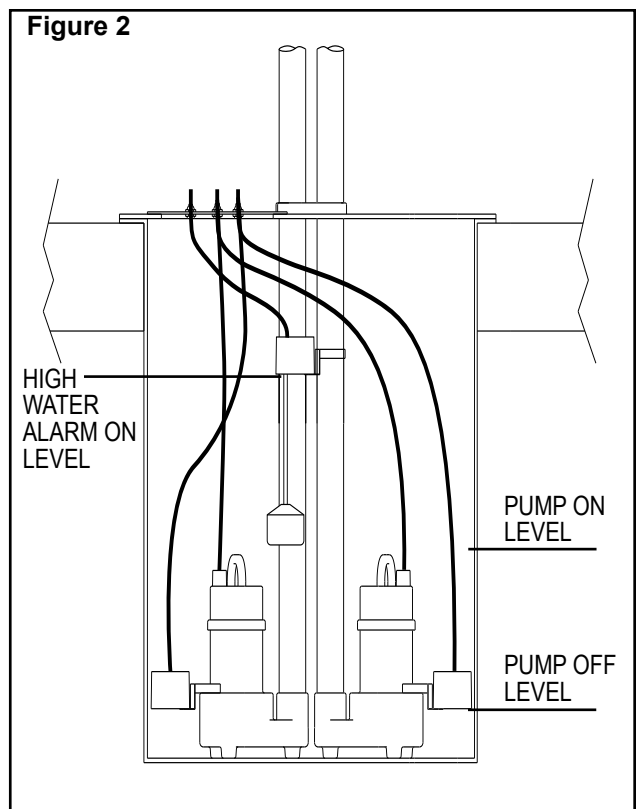
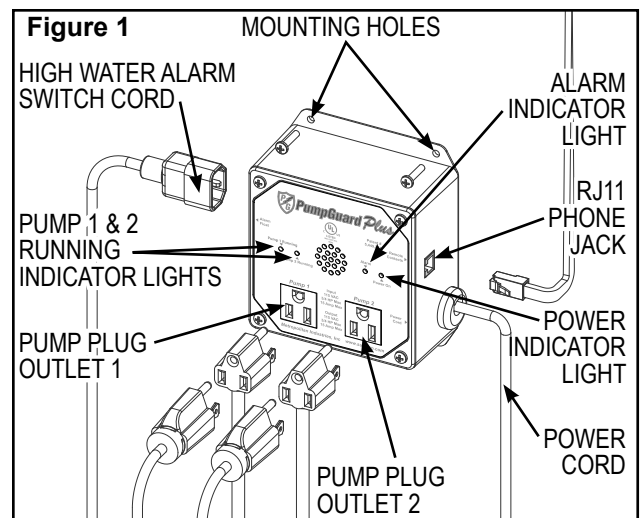

# PumpGuard Plus

Pump alternator with high water alarm  
Model #20102

## INSTALLATION INSTRUCTIONS

Dated: 05/15/07

Supersedes: 04/12/07

Document No.: PGP-OM

Page 3 of 5

high water float cords. First plug each pump cord into the corresponding piggyback switch cord. Once the pump and switch cords are connected, plug them into the PumpGuard Plus. Plug one set of pump and piggyback switch cords into Pump 1 and the other set into Pump 2. Now attach the High Water Alarm Float Switch cord into the Alarm Float receptacle located on the left side of the PumpGuard Plus controller (see figure 1). Secure cords to provide additional support and strain relief for the cords and outlets.

Now that all of the wiring has been connected, plug the PumpGuard Plus AC power cord into the designated electrical outlet. You should now see the *Power On* indicator illuminate. If you are not using the Remote Contacts, proceed to Testing.

### High Water Alarm Remote Contact

Note: Please see Specifications section for electrical ratings of remote contacts before using. Please consult a qualified electrician or low voltage specialist for additional assistance.

The PumpGuard Plus is equipped with a remote contact that can be connected to a home alarm/automation system or the optional external dialer for added protection (see accessories section for details). The receptacle is a standard RJ-11 6X4 jack. Industry standard cabling (not included) contains four wires, usually black, red, green and yellow wires. The red and green pair is used by the PumpGuard Plus to signal external devices of an alarm situation. See figure 4 for a typical cable connector pin-out. In the event of a high water alarm or power failure, the contact opens. Please refer to the Specification section for more information.

### TESTING

Fill the pump tank with water and allow the system to cycle several times to ensure proper operation. First pump 1 will energize and pump down the pit, note the pump 1 running indicator on the front of the PumpGuard Plus. After the water level has risen to a level high enough to activate the pump floats, Pump 2 will energize and pump down the pit, also illuminating the Pump 2 running indicator.

Please note that the PumpGuard Plus has a built in 15 second delay between alternations to reduce the tendency to short cycle pumps when switches are set

Figure 3

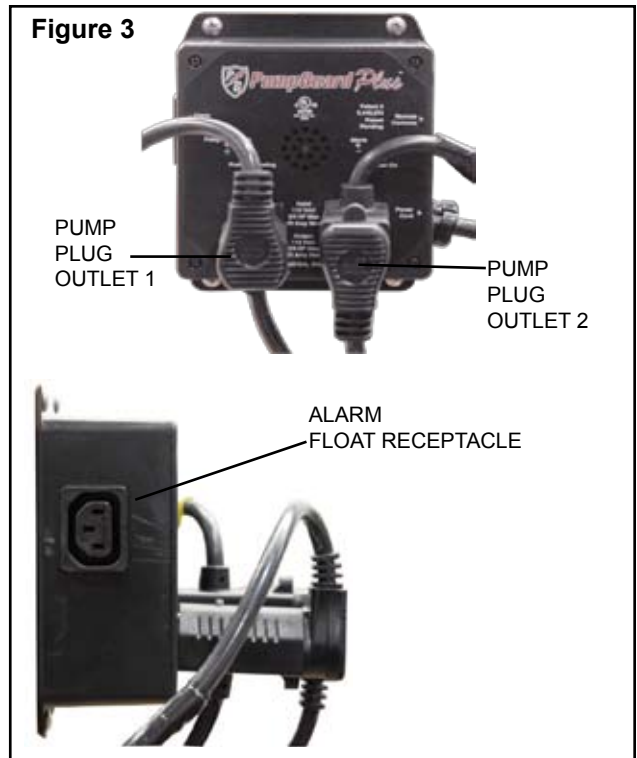
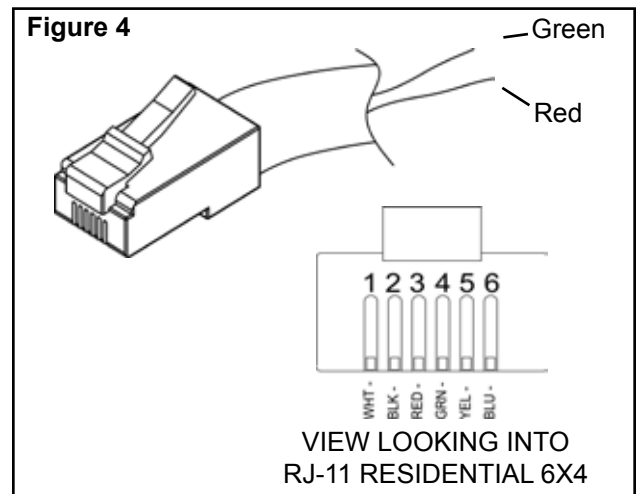

Figure 4



# PumpGuard Plus

Pump alternator with high water alarm  
Model #20102

## INSTALLATION INSTRUCTIONS

Dated: 05/15/07

Supersedes: 04/12/07

Document No.: PGP-OM

Page 4 of 5

at similar heights. This will allow both pumps to run a complete cycle before alternating.

Allow the pit to fill again, high enough to activate one of the pumps, then activate the alarm by lifting the Alarm Float Switch. The alarm will sound, and the PumpGuard Plus will stop the running pump and alternate to the next pump in sequence. If you release the High Water Alarm Float before the pump is finished pumping down the pit, the alarm will stop sounding, but the pump will finish its pump down cycle. You are now finished installing the PumpGuard Plus!

### Typical Installation

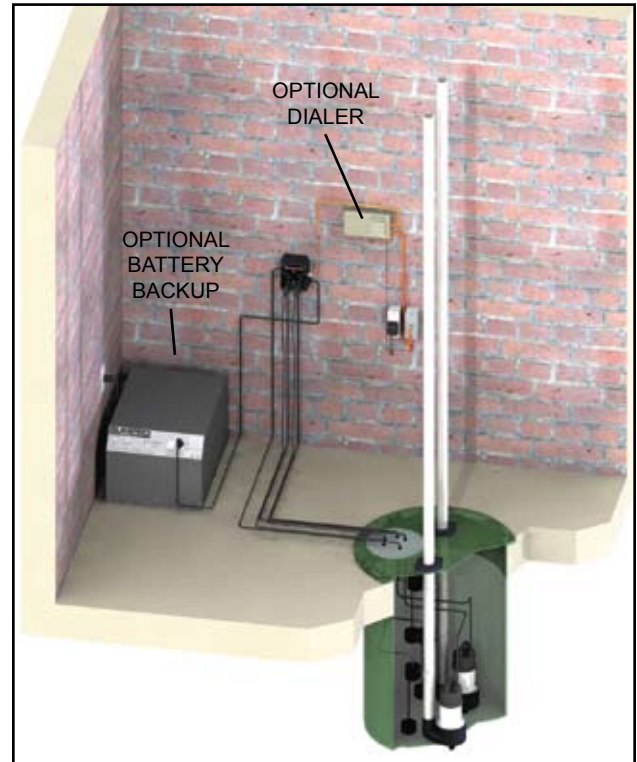

### TROUBLESHOOTING

Symptom	Cause	Measures
Power On not illuminated	Tripped breaker	Reset breaker
	Faulty outlet	Check outlet/wiring
	Power cord not securely in outlet	Check outlet connection
Pump(s) will not run	Faulty pump switch	Remove piggyback switch, plug pump into outlet If pump runs - replace pump switch If pump does not run - replace pump
	Faulty pump	Plug pump directly into outlet If pump does not run - replace pump
Pump(s) run but will not pump down water	Jammed pump	Clear pump or pipe, replace if necessary
	Bad check valve	Check for proper operation of check valve, replace if necessary
Alarm will not sound	Pump switches not triggered	Add water to pit to trigger switches, then activate alarm switch
	Faulty pump switches	Test and replace switches as necessary
	Faulty alarm float switch	Remove alarm float, activate switch, use ohm meter to test for continuity between the two outside plug terminals - if you have no continuity, replace switch
Remote contacts not working	Faulty wiring	Use ohm meter to test continuity of terminals You should see continuity in normal operation, activate high water alarm - you should measure an open Consult a qualified electrician or low voltage integrator for all external connection problems

# PumpGuard Plus

Pump alternator with high water alarm  
Model #20102

## INSTALLATION INSTRUCTIONS

Dated: 05/15/07

Supersedes: 04/12/07

Document No.: PGP-OM

Page 5 of 5

### ACCESSORIES

You can even further increase your protection of the PumpGuard Plus with the following qualified add-on accessories:



**StormPro**  
For use with AC pumps rated up to 5 Amps.



**Sumpro**  
For use with AC pumps rated up to 12 Amps.



**Optional Dialer**  
Can be programmed with up to nine numbers including a personalized voice message. Activates upon high water alarm or power outage.

Check out our website for more details:  
[www.metropolitanind.com/residential\\_alarms\\_controls.htm](http://www.metropolitanind.com/residential_alarms_controls.htm)

For operation and installation instructions on how to integrate these accessories, please refer to [www.metropolitanind.com](http://www.metropolitanind.com) or call 1-800-323-1665 for assistance.

### SPECIFICATIONS

<b>Model Number:</b>	#20102
<b>Voltage:</b>	120 VAC, 60Hz
<b>Capacity:</b>	15A max load
<b>Consumption:</b>	Total-load dependant Idle – 1.2W max
<b>Remote Alarm Contacts:</b>	N/C contacts rated 0VAC/DC 1A
<b>Temperature Range:</b>	0°C to 60°C
<b>Indicator lights:</b>	Power On Pump 1 Running Pump 2 Running Alarm
<b>Audible Alarm:</b>	80db at 10ft.
<b>Alarm Switch:</b>	(same info)
<b>Enclosure:</b>	NEMA-1 UL94V-0 Acrylonitrile butadiene styrene
<b>Dimensions (controller):</b>	4.62x4.62in
<b>Mounting flange pattern:</b>	5.25x3.50in
<b>Float height:</b>	10.5in max
<b>Weight (controller):</b>	1.75lbs.
<b>Mounting:</b>	up to (4) #10 screws (not included)

### LIMITED WARRANTY

PumpGuard is warranted to be free from defects in material and workmanship and to perform within applicable specifications for a period of one (1) year. Obligation under this warranty is limited to repairing or replacing any part thereof, which shall within one year be returned to us with transportation charges prepaid, and prove to be defective.

The above limited warranty takes the place of all other warranties, express or implied and correction of such defects by replacement or repair shall constitute a fulfillment of all obligations under the terms of the warranty, which specifically EXCLUDES any incidental damages caused by or associated with this product or its use. The warranty does not cover any unit which has been damaged either in transit or by misuse, accident or negligence. No warranty or representation not contained herein shall be binding.

LABOR, ETC. COSTS: Metropolitan shall IN NO EVENT be responsible or liable for the cost of field labor or other charges incurred by any customer in removing and/or affixing any Metropolitan product, part or component thereof.

Register your product at  
[www.sumpro.com](http://www.sumpro.com)

 **Metropolitan**  
[www.metropolitanind.com](http://www.metropolitanind.com)