

MYERS® S40HT SERIES

The Myers S40HT series effluent pump is a small, rugged, submersible, cast iron pump with a non-clog vortex impeller and solids handling capability to 3/4". Unit has 1/3 HP, 115 Volt, single-phase motor and 1-1/2" NPT vertical discharge. Available with high temperature float switch.



APPLICATIONS

Boiler blow down pits, condensate pits, hot water sumps

SPECIFICATIONS

Capacities – 45 GPM (170 LPM)
Shut-off Head – 21' (6.4 m)
Operation – S40HT-11P
 On: 13.5" (343 mm); Off: 4.5" (114 mm)
Operation – Manual and automatic
Solids Handling – 3/4" (19 mm)
Liquids Handling –
 High temperature liquids
Intermittent Liquid Temperature –
 S40HT-11P: up to 194°F (90°C)
 S40HT-11: up to 200°F (93°C)
Motor/Electrical Data – 1/3 HP, 12.0A,
 thermal overload protection, oil-filled,
 115V, 1Ø, 60Hz, 1550 RPM
Acceptable pH Range – 6-9
Mechanical Seal – Type 6A or equal,
 Buna-N elastomers, carbon and ceramic
 sealing faces, stainless steel metal parts
Bearings – Lower ball, upper sleeve type,
 oil lubricated
Housing/Volute Case/Impeller – Cast
 iron
Exterior Hardware – Stainless steel
Power Cord – 20', 16/3, SJ00W-A/SJOW
 with integrally grounded three-prong plug
Discharge, NPT – 1-1/2" (38.1 mm)
Minimum Sump Diameter – Simplex: 18"
 (45.7 cm); Duplex: 30" (76.2 cm)

FEATURES

Cast Iron Tough

All cast-iron housing, volute case, and impeller resists the most extreme corrosive environments

Rugged and Cool

Rugged-built, oil-filled motor for continuous bearing lubrication and maximum heat dissipation

Thermal Protection

Heat sensor overload protection with automatic reset when motor cools to a safe operating temperature

Longer-lasting Motor

Lower ball bearing eliminates sleeve bearing wear and reduces motor wear

Impeller

Non-clog vortex style, ejector vanes for seal protection

Stainless Steel Hardware

Allows easy disassembly after extended service

Oil and Water Resistant Cord Design

Prevents oil loss from – and moisture protection for – motor

Bearings and Mechanical Seal

Permanently lubricated for long life

Easy Service

Heavy-duty lift-out ring

ORDERING INFORMATION

Catalog Number	HP	Volts	Phase/Cycles	Amps	Discharge Size	Switch Type	Cord Length	Approx. Wt. Lbs.
S40HT-11	1/3	115	1/60	12	1-1/2"	Manual	20'	36
S40HT-11P	1/3	115	1/60	12	1-1/2"	Tethered	20'	36

MYERS® S40HT SERIES

DIMENSIONS

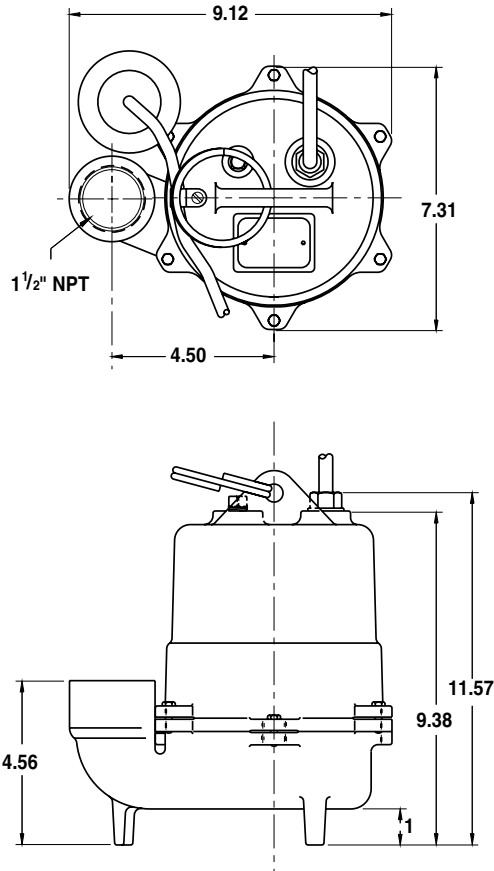

PUMP PERFORMANCE

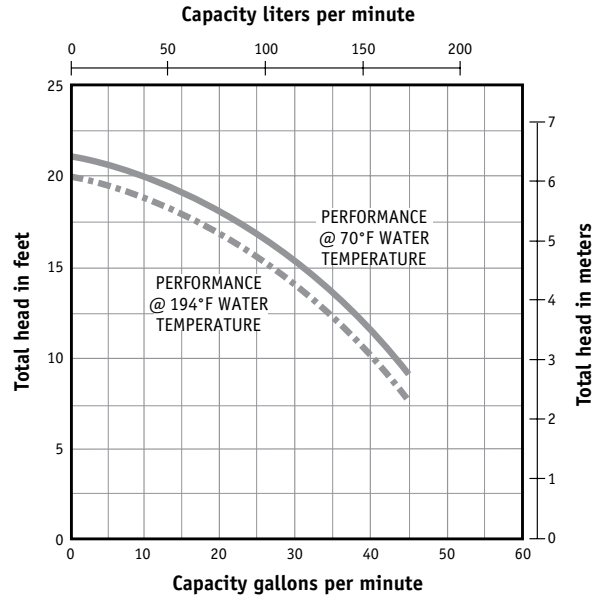

USA
293 WRIGHT STREET, DELAVAN, WI 53115 WWW.FEMYERS.COM
PH: 888-987-8677 ORDERS FAX: 800-426-9446

CANADA
490 PINEBUSH ROAD, UNIT 4, CAMBRIDGE, ONTARIO N1T 0A5
PH: 800-363-7867 ORDERS FAX: 888-606-5484

Because we are continuously improving our products and services, Pentair reserves the right to change specifications without prior notice.