

Take Control.
ION
StormPro®



SHV40i+

Sewage Pump With Built-In High Water Alarm

- Light commercial sewage
- Residential sewage
- High-capacity sump
- Septic tank effluent



Patent No. 8,591,198



37 Forestwood Dr., Romeoville, IL 60446 www.ionstormpro.com [815] 886-9200

SHV40i+

Sewage Pump With Built-In High Water Alarm

System Specifications

Typical Applications	<ul style="list-style-type: none">• Light commercial sewage• Residential sewage• High-capacity sump• Septic tank effluent
----------------------	--

Maximum Capacity	Up to 90 GPM
------------------	--------------

Maximum Head	Up to 25'
--------------	-----------

Electrical Data	115 V, 1 \emptyset , 8.5 FLA, 60 Hz
-----------------	---------------------------------------

Motor Data	1/2 HP, 3450 RPM
------------	------------------

Intermittent Liquid Temperature	130° F
---------------------------------	--------

Recommended Minimum Basin Size	18" x 30"
--------------------------------	-----------

Automatic Operation	i+: Ion+ (standard)
---------------------	---------------------

Materials of Construction	Cast iron and stainless steel
---------------------------	-------------------------------

Impeller	Cast iron vortex
----------	------------------

Power Cord	20' Standard
------------	--------------

Discharge	2" NPT
-----------	--------

Solids Handling	2"
-----------------	----

Pump Dimensions

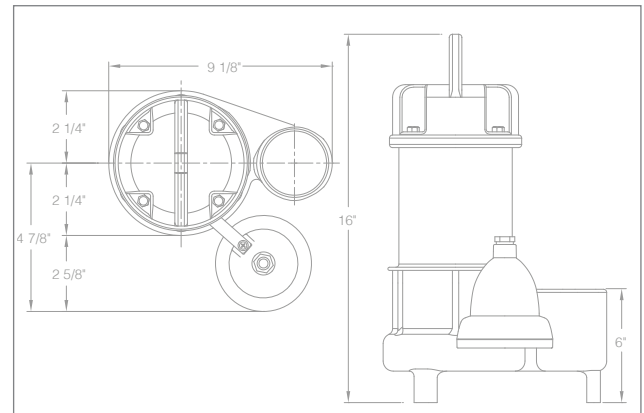

Pump Performance

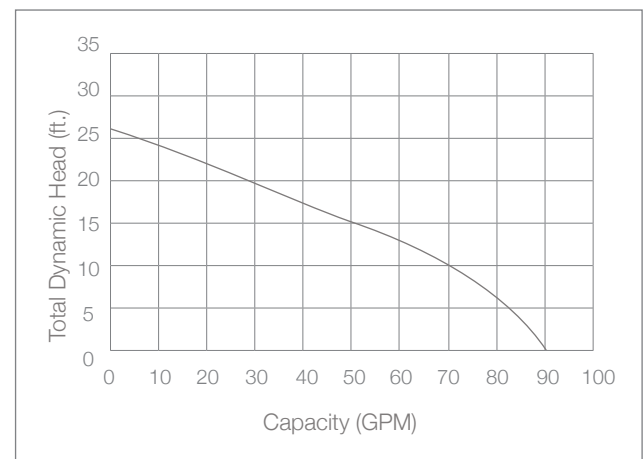

Features

- Carbon ceramic mechanical seal
- Automatic reset thermal overload for maximum protection
- Lower single-row ball-bearing construction
- Piggyback Ion+[®] digital level control switch with alarm has no moving parts (standard)
- 3 year warranty