

LIMITED WARRANTY AND LIMITATION OF LIABILITY

Decko Products warrants this product free from material and /or manufacturing defects for one year from date of purchase (three years on cast iron pumps). As the sole and exclusive remedy for a breach of this limited warranty, if the product is found by Decko Products to be defective, Decko Products, at its option, will refund the purchase price or replace the product with an equivalent product if it is returned to the place of purchase or returned postpaid to Decko Products, ATTN: Warranty Dept., 2805 North Fairview Ave., Roseville, MN 55113, with proof of purchase. Any disassembly, modification, or abuse of this product voids this limited warranty. This product is not designed for pumping flammable or corrosive fluids, and use of this product to pump such materials also voids this limited warranty

**DECKO PRODUCTS DISCLAIMS ALL OTHER
EXPRESS OR IMPLIED WARRANTIES,
INCLUDING WARRANTIES OF
MERCHANTABILITY OR FITNESS FOR A PARTICULAR PURPOSE.**

IMPORTANT NOTICE: Some commercial and residential insurance policies extend coverage for damages incurred by product failure. In most cases, you will need to have possession of the product to support your claim. In the case where you need to retain possession of the product to support a damage claim you submit to your insurance company, Decko Products will exchange the unit or refund the original price once the claim is settled with the insurer.



**2805 North Fairview Ave.
Roseville, MN 55113
1-800-495-9278
www.superiorpump.com**

QUALITY PUMPS FROM



OWNERS MANUAL

INSTALLATION AND OPERATION INSTRUCTIONS FOR PEDESTAL SUMP PUMPS

Models:

**92333, 92301, 92302
92551, 92552, 92553**



If for any reason you have questions concerning your new Superior Pump, call us toll free at 1-800-495-9278, or contact us on the web at www.superiorpump.com.

Carefully read and understand all of the Warnings and installation instructions in this manual. Failure to follow these instructions could lead to serious bodily injury and/or property damage. Retain these instructions for future reference.

This pump has been manufactured with your needs in mind. Properly installed in the right application, your new Superior Pump will give you years of carefree performance.

DANGER ⚠ This pump motor is not submersible. Do not submerge the motor or allow motor to be exposed to water. Personal injury and/or death from electrical shock could result.

DANGER ⚠ Water and electricity can be dangerous if certain precautions are not adhered to. This pump is designed to operate perfectly safe in a water environment; however, improper use and installation can result in personal harm from electrical shock. Please pay attention to the following warnings.

WARNING ⚠ Never touch any electrical device, including this pump, when it is touching water, in water, or even in a moist environment. Always unplug (disconnect the electricity) when servicing or installing the unit.

WARNING ⚠ **RISK OF ELECTRICAL SHOCK.** This pump is supplied with a grounding conductor and grounding-type attachment plug. To reduce the risk of electrical shock, be certain that it is connected only to a properly grounded, grounding-type receptacle.

WARNING ⚠ Do not use the power cord or discharge hose to carry or handle the pump. Doing so may cause damage to the power cord or discharge hose.

WARNING ⚠ Always use a grounded outlet to attach the plug. A three-prong mating type receptacle is needed for safe use. This should be in accordance with the National Electric Code and any additional codes or laws required by your local government.

NOTICE ⚠ It is strongly recommended to use a ground fault interrupt (GFCI) device on any electrical appliance, including this pump, when used in a wet or moist environment. This is required by many local codes and enforcement agencies. It is strongly recommended by Decko Products as it provides a much safer installation and will greatly reduce possible injury from electrical shock.

REPLACEMENT PARTS
To order replacement parts,
Call 1-800-495-9278

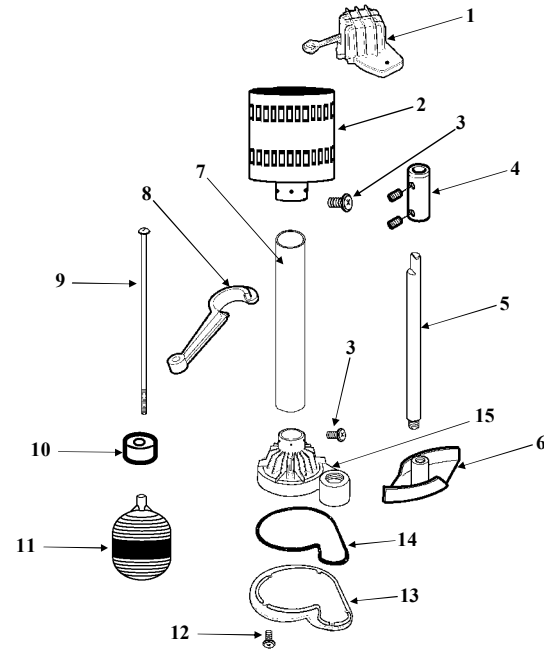

Ref #	Description	92333	92301	92302	92553	92551	92552
1	Switch	99100	99100	99100	99100	99100	99100
2	Motor	YYB-200	YYB-200	YYB-200	YYB-300	YYB-300	YYB-300
3	Screw (Qty 3)	99110	99110	99110	99110	99110	99110
4	Coupling	99112	99112	99112	99112	99112	99112
5	Drive Shaft	99114	99114	99114	99114	99114	99114
6	Impeller	99116	99118	99118	99116	99118	99118
7	Column	99119	99120	99122	99119	99124	99122
8	Float Rod Guide	99126	99128	99128	99126	99128	99128
9	Float Rod	99129	99129	99129	99129	99129	99129
10	Grommet	99130	99130	99130	99130	99130	99130
11	Float Ball	99132	99134	99134	99132	99134	99134
12	Screw (Qty 6)	99136	99137	99137	99136	99137	99137
13	Base (Volute)	99140	99142	99144	99140	99142	99144
14	Gasket	N/A	99138	99138	N/A	99138	99138
15	Base (Housing)	99146	99148	99150	99146	99148	99150

NOTICE ⚠ Height and/or piping restriction will reduce the pump output performance. See the performance chart below to insure you have the proper pump for your application. Whenever possible use the same or larger size pipe than the pump discharge for optimum performance. Reducing the pipe size will not harm your pump; it will just reduce the output.

PERFORMANCE CHART

Model #	Gallons Per Minute @ Total Head In Feet						Shut Off
	0'	5'	10'	15'	20'	25'	
92333	50	45	38	35	15	-	22.1'
92301	50	45	38	35	15	-	22.1'
92302	50	45	38	35	15	-	22.1'
92553	65	60	53	45	28	10	27.6'
92551	65	60	53	45	28	10	27.6'
92552	65	60	53	45	28	10	27.6'

SPECIFICATIONS

Power supply requirements.....120V, 60 Hz
 Circuit Requirements15 amp minimum
 Motor.....Continuous Duty, Capacitor Start,
 Thermally Protected
 Maximum liquid temperature.....120°F (92333, 92553)
 180°F (92301, 92302, 92551, 92552)

Model	HP	Amps.	Column Material	Base Material	Discharge Size	Float	Impeller Material
92333	1/3	2.76	Plastic	Plastic	1 1/4"	Plastic	Plastic
92301	1/3	2.76	Steel	Cast Iron	1 1/2"	Copper	Stainless Steel
92302	1/3	2.76	Brass	Bronze	1 1/2"	Copper	Stainless Steel
92553	1/2	3.13	Plastic	Plastic	1 1/4"	Plastic	Plastic
92551	1/2	3.13	Stainless Steel	Cast Iron	1 1/2"	Copper	Stainless Steel
92552	1/2	3.13	Brass	Bronze	1 1/2"	Copper	Stainless Steel

DANGER ⚠ Do not use this unit to pump chemicals, flammable liquids, sewage or corrosive liquids. You could injure yourself and the pump will fail. Pumping these types of liquids voids the warranty. Decko Products and other pump companies manufacture pumps for these types of liquids. Make sure you purchase a pump designed for your specific needs. This pump will handle fluids with the same characteristics as water. If you have any questions call us at 1-800-495-9278 or contact us on the web at www.superiorpump.com

NOTICE ⚠ Your pump has thermal over-load protection built in. The thermal overload protector will automatically shut down the motor in an overheat situation. It will then reset itself once the motor cools down. The pump will then work again. This overload protector is designed as a safety device and it will fail after repeated use.

NOTICE ⚠ **EXTENSION CORDS**

For best performance, it is recommended to connect the power cord directly to the grounded GFCI outlet. If the use of an extension cord is necessary, always use a grounded waterproof type cord. Never use longer than a 25-ft. cord that is lighter than 14/3 gauge.

DANGER ⚠ Keep all electrical connections away from wet and moist environments. Wet connections can cause electrical shock resulting in personal injury.

USE AND INSTALLATION

WARNING ⚠ ALWAYS DISCONNECT THE POWER SOURCE BEFORE ATTEMPTING TO INSTALL, SERVICE OR PERFORM MAINTENANCE ON THE PUMP. FAILURE TO DO SO MAY RESULT IN FATAL ELECTRICAL SHOCK.

Your Superior Pump is designed and built to give you reliable performance and long life. It will pump water automatically for years when properly installed in the right environment.

REMOVING OLD PUMP. (If necessary)

1. Make sure power supply is disconnected.
2. After the power is off, remove the old pump. There are many different possible types of installations.
3. It is best to remove all old piping and start over with new piping. Be sure to clean all debris and dirt out of the sump basin before installing your new pump.

Be sure to have a grounded 120V AC outlet mounted within 6 ft. of your sump basin. Again, it is highly recommended that a GFCI (ground fault circuit interrupter) outlet be installed in the receptacle box.

NOTICE ⚠ A qualified electrician must perform all wiring.

INSTALLATION (New Pump)

1. a. Insert the float rod through the hole in the switch.
b. Carefully slide the rubber grommet onto the float rod.
c. Slide guide onto the float rod and attach it to the column.
NOTE: On Model #'s 92333 & 92553 there is a hole in the column where the float rod guide "snaps" into. Make sure that the float rod guide is properly secured to the column to prevent the float rod from moving.
d. Thread the float ball onto the float rod. You may need a set of pliers to prevent the rod from turning.
e. Move the grommet up or down on the float rod to adjust the "turn on" position of the pump.
2. Set your new pump in the bottom of the sump basin. The pump should be placed on a solid foundation. Do not place pump directly on the ground or sandy or rocky surfaces. Sand and small stones may clog or cause damage to your pump.
3. Make sure the float ball will move up and down freely without coming in contact with the side of the sump pit. Contact with the side of the sump pit may cause the switch to malfunction. See figure 1 below.

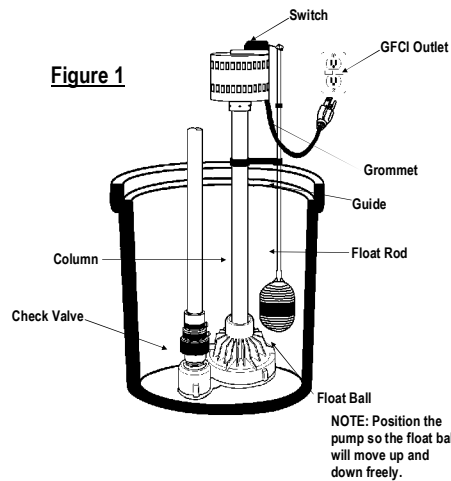

4. It is highly recommended to install a full flow, swing type check valve (not included) as close to the discharge outlet on the pump as possible. A new check valve will greatly increase the life of your pump, and should be the same size as the pump discharge, 1 ¼" or 1 ½".
5. Connect the pump and check valve together using schedule 40 PVC pipe and fittings. You can also use DWV or ABS pipe, as this is not a pressure installation. Corrugated drain hose is intended for temporary use and should not be used in a permanent

installation. Although there are many types of pipe that work adequately for this installation, PVC is recommended.

6. Test your installation after you have completed setting up the pump and connected all piping. Plug the cord into the grounded outlet. The pump should not run at this point. If the pump runs, the switch is stuck in the upright position. Fill the sump basin with water using buckets or a hose. When the float moves to the upright position, the pump will turn on. The switch will turn off the pump when the float reaches the down position. You may adjust the "turn on" position to meet your particular needs by moving the grommet up or down on the float rod. Remember the switch must move up and down freely without touching the sides of the sump basin.

TROUBLESHOOTING

WARNING  ALWAYS DISCONNECT THE POWER SOURCE BEFORE ATTEMPTING TO INSTALL, SERVICE OR PERFORM MAINTENANCE ON THE PUMP. FAILURE TO DO SO MAY RESULT IN FATAL ELECTRICAL SHOCK.

If the pump does not start or run.

1. Make sure pump is plugged in.
2. Check for blown fuses or tripped circuit breakers or tripped GFCI outlets.
3. Check to make sure the float ball moves up and down freely

If the pump starts and stops too frequently:

1. Check for backflow of water from discharge hose/pipe. Install or replace check valve.
2. Adjust the "on/off" position of the pump by moving the grommet up or down on the float rod

If the pump will not shut off:

1. Make sure float ball drops to full down position. It may be obstructed.
2. Check for obstructions in piping.

If the pump runs and moves little or no water

1. Make sure check valve is installed in correct direction.
2. Check to insure discharge pipe is not plugged.