

EP52 $\frac{1}{2}$ hp

EP72 $\frac{3}{4}$ hp

Barnes EP52 & EP72 Effluent/Sump Pumps feature 230 volt 1 phase operation in a rugged cast iron, heavy duty, high performance design.

Product features for superior performance

- Maximum flow rate to 90 GPM (EP72) and 83 GPM (EP52).
- Maximum shut off head of 31 ft.
- Stainless steel shaft and hardware provide excellent corrosion resistance.
- Permanent Split capacitor motor for reliable, high performance, longer motor life, greater starting torque, and lower amp draw.
- Interchangeable with other effluent pumps.

Barnes Effluent pumps save time and replacement costs because they are interchangeable with competing effluent models. They require no additional plumbing when replacing most competitor's pumps.

Design Options

- Vertical or tethered floats are easily adjusted for varying conditions.
- All switches come with standard 20' cord.
- Manual models available if preferred.



Effluent/Sump Pump Series

Design Features

- Vortex impeller design provides $\frac{3}{4}$ " spherical solids handling capability
- Upper and lower ball bearings are oil lubricated for maximum life
- Silicon carbide mechanical seal faces provide outstanding grit resistance
- Industrial-style motors, contained in a cast iron housing, are oil filled for optimum cooling and long life
- Pump provided with protective high temperature overload switch
- Unit provided with power cord including molded NEMA 6-15P plug for 230V single phase operation.
- Cast Iron vortex impeller
- CSA Listed
- Stainless steel shaft and hardware
- 12 month limited warranty

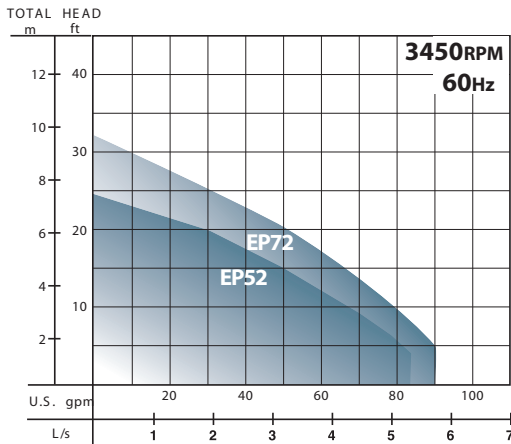
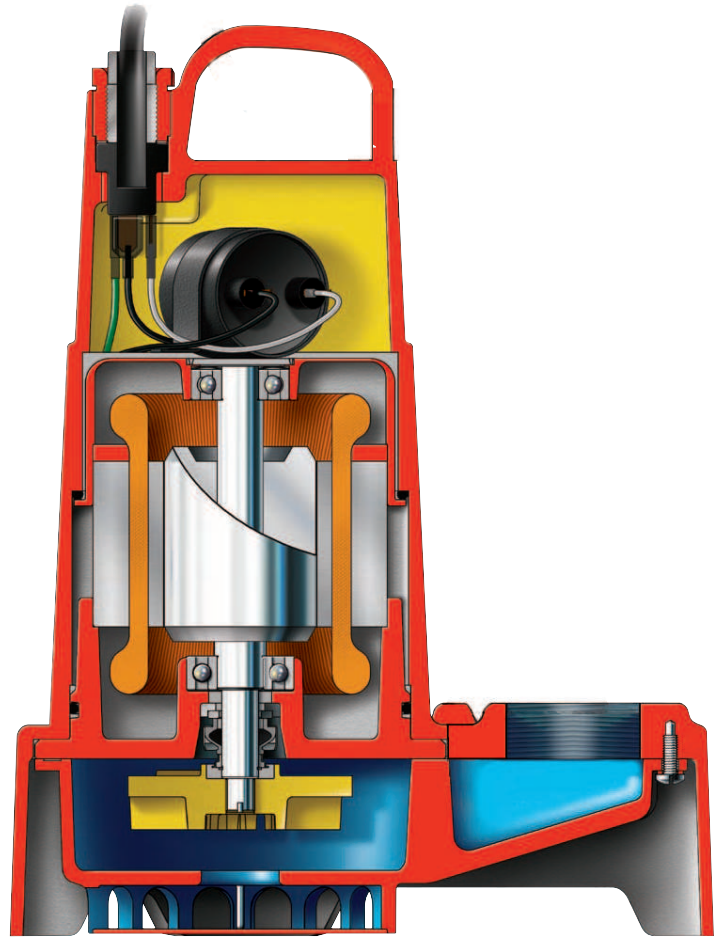

CRANE[®]

A Crane Co. Company

PUMPS & SYSTEMS

Crane Pumps & Systems

420 Third Street
Piqua, Ohio 45356
(937) 778-8947
Fax (937) 773-7157
www.cranepumps.com

Crane Pumps & Systems Canada

83 West Drive
Brampton, Ont. Canada L6T 2J6
(905) 457-6223
Fax (905) 457-2650



© 2012 Crane Pumps & Systems, Inc.
A Crane Co. Company
Printed in U.S.A.
BPPEP52-72 - Rev. C (11/12)

brands you trust.

BARNES[®]

burks[®]

DEMING[®]

WEINMAN[®]



PROSSER[®]