

CONSTRUCTION

- Corrosion-resistant stainless steel motor housing and fasteners for long life in tough sump applications
- **Top suction design** eliminates air locks and minimizes clogging from debris in the bottom of the sump pit
- Reliable thermoplastic impeller for maximum water flow
- 1-1/2 in. NPT discharge for easy installation and compliance with building codes
- 8 ft. SJTW power cord
- **5.2 Gallon Basin Capacity**

SWITCH

- Integrated vertical float switch for reliable automatic/manual operation
- ON @ 9 in. / OFF @ 4 in.

MOTOR

- 120 Volt, PSC oil-filled motor
- Low amp draw for extended switch life

1/3 HP DRAIN PUMP PreASSEMBLED PACKAGED SYSTEM

45 GPM @ 10 FT.



1/3 HP



DIMENSIONAL DATA (INCHES)

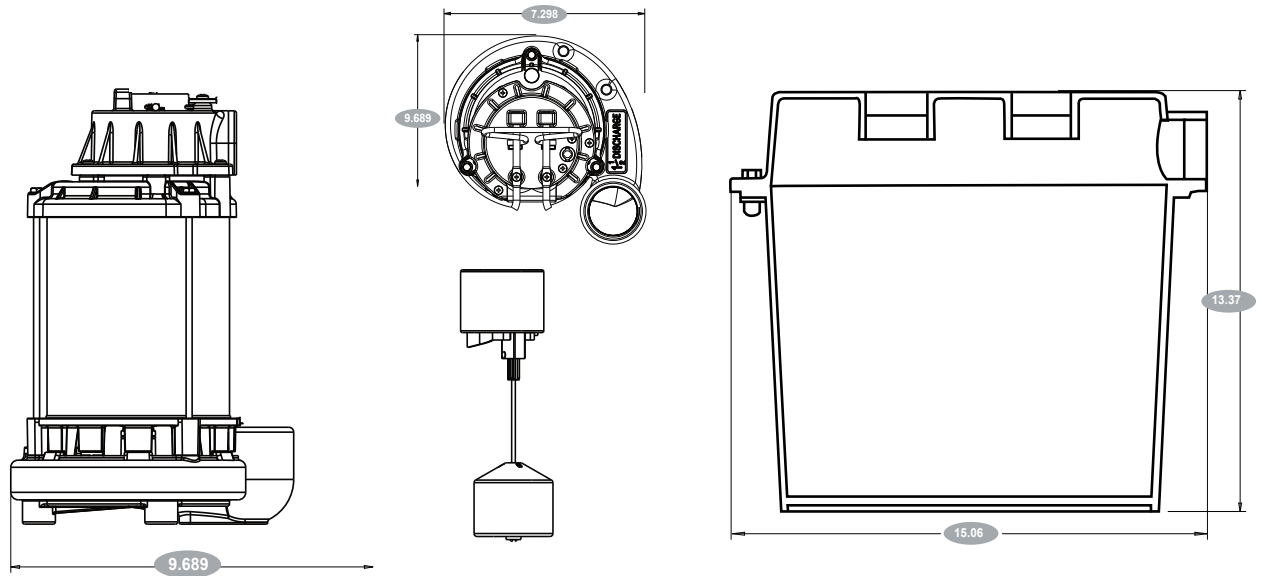

PUMP SNAPSHOT

Pump Dimensions (in.)									
HP	Construction	Switch Type	Length	Width	Height	Weight	Volts	Footprint	Power Cord
1/3	Stainless Steel	Vertical Float	9.689	7.298	11.634	17 lbs	120	11 in.	8 ft.
Impeller	Intake	Discharge	Submersible	UPC 0-40066					
Centrifugal	Top Suction	1-1/2 in. NPT	Yes	21788 2					

TYPICAL INSTALLATION

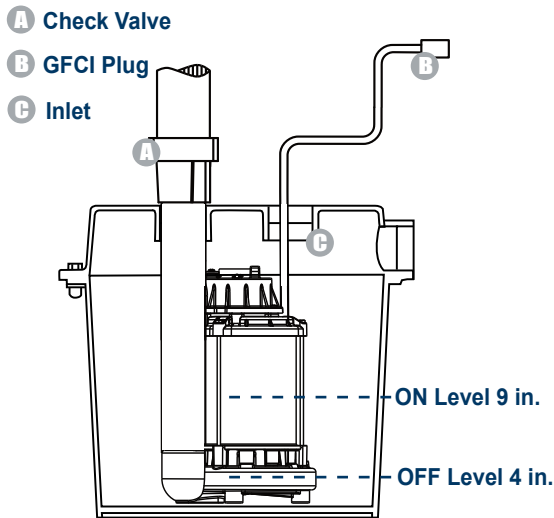

SSF33SDP PERFORMANCE

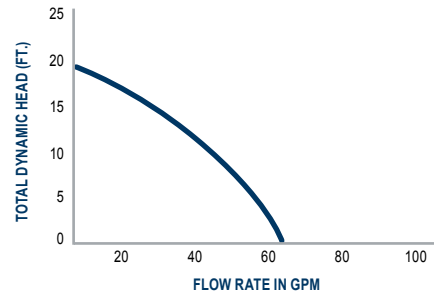

Discharge Head	5 ft.	10 ft.	15 ft.	20 ft.
GPM	57	45	28	0