

CONSTRUCTION

- Stainless steel shaft and fasteners, for reliability long term in tough sewage applications
- Heavy-duty upper and lower ball bearings for long life and quiet operation
- 2 in. NPT discharge capable of handling 2 in. solids
- Glass-reinforced impeller for long lasting reliability
- 20 ft. SJTW power cord is oil and water resistant, with neoprene grommet for superior seal
- For use in 18 in. diameter or larger sump basins

BASIN

- 18 in. x 30 in. polystructural foam basin / lid with anti flotation device
- 2 in. side discharge and electrical connection
- Full flow 2 in. check valve installed in basin
- 4 in. snap-in hub with pipe clamp

SWITCH

- Piggy-back tether float switch for automatic or manual operation
- ON @ 19 in. / OFF @ 10.5 in.

SEALS

- Carbon / ceramic shaft seal for maximum life

MOTOR

- PSC oil-filled motor, thermally protected motor prevents overheating



4/10 HP CAST IRON SUMP PUMP PACKAGED SEWAGE SYSTEM

98 GPM @ 10 FT.

4/10 HP

DIMENSIONAL DATA (INCHES)

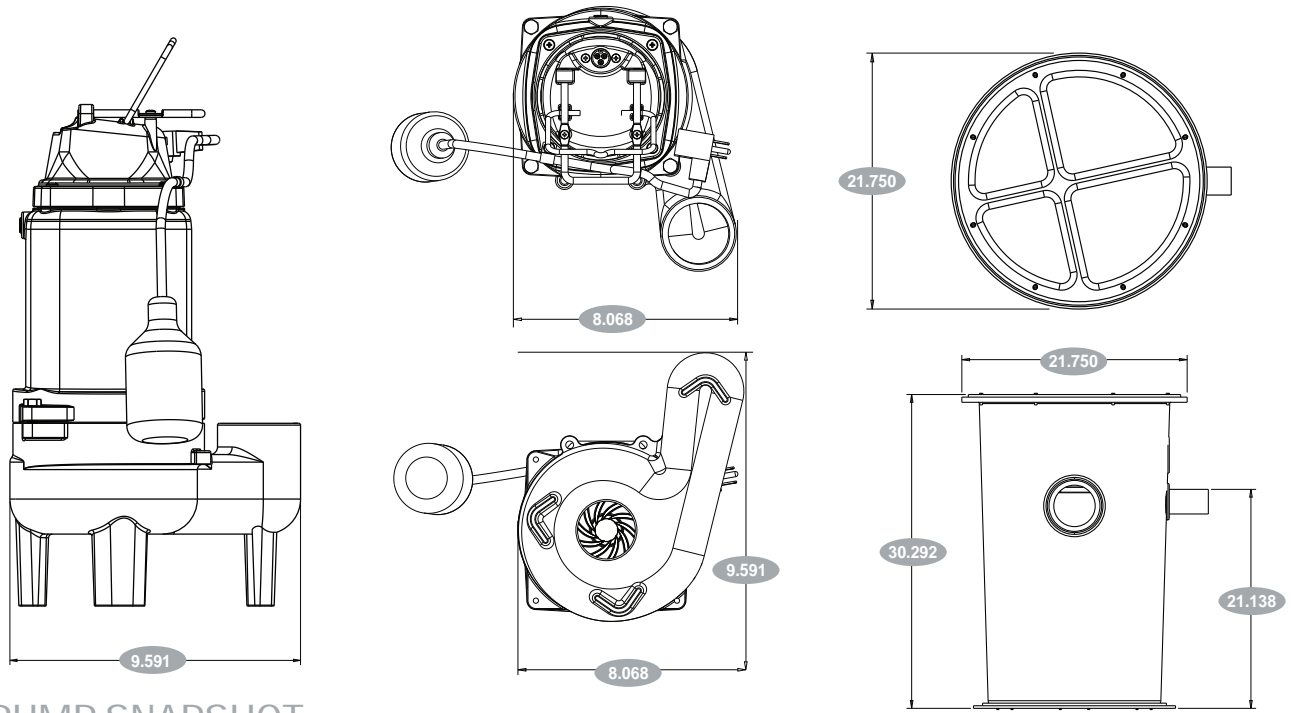

PUMP SNAPSHOT

Dimensions (in.)									
HP	Construction	Switch Type	Length	Width	Height	Weight	Volts	Footprint	Power Cord
4/10	Cast Iron	Tether Float	9.591	8.068	16.551	38 lbs	120	18 in.	20 ft.
Impeller	Intake	Discharge	Submersible	UPC 0-40066					
Vortex	Bottom Suction	2 in. NPT	Yes	217844					

TYPICAL INSTALLATION

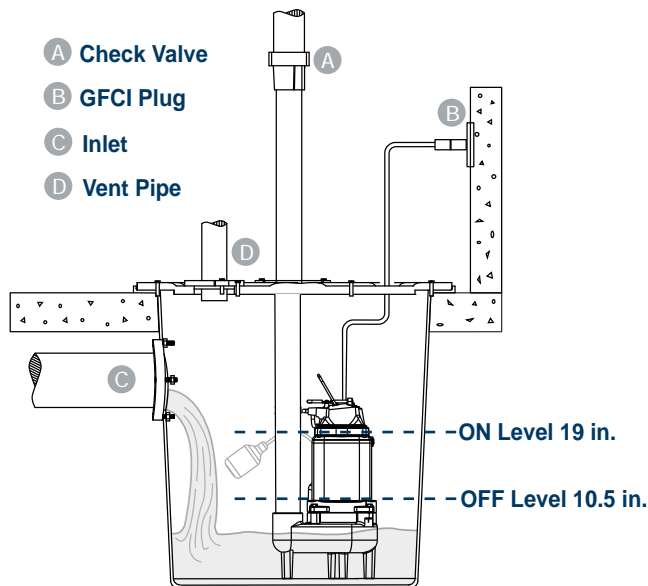

T40SW PERFORMANCE

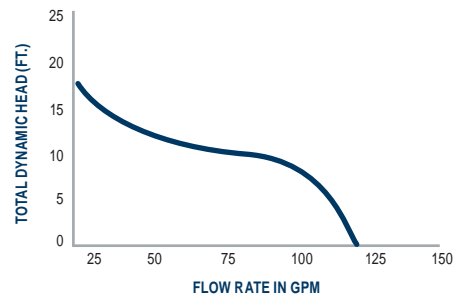

Discharge Head	5 ft.	10 ft.	15 ft.	20 ft.
GPM	100	98	28	0