

# Liberty Pumps®

## Model 405



**Energy Saving!  
Model**  
Efficient motor design  
reduces electrical usage  
by up to **40%**

**3**  
Year Warranty

**Commercial  
Drain Pump**  
**High-Head**  
**High Temperature**  
**1/2 hp**  
**3/8" solids-handling**  
**Featuring QuickTree®  
technology for easy  
switch access!**

#### Features:

- Factory pre-assembled, ready to install
- Fully automatic operation
- Handles fluid temperatures to 180 degrees F. (not designed for use with chemicals.)
- Separate access cover for easy switch inspection
  - 2" inlet and 2" vent
  - 2" discharge
- Integrally molded rubber gasket for a superior gas-tight seal
- Standard alarm and Wi-Fi alarmed models available

#### Applications Include:

Bar sinks, laundry trays, multi-compartment utility sinks, dehumidifiers, dishwashers and gray wastewater drainage below gravity lines

**NEW!**

**NightEye®**  
Wireless Enabled  
Models Available



innovate. evolve.

# MODEL 405 & 405HV

## COMMERCIAL DRAIN PUMP

### FEATURES:

- Factory pre-assembled.
- Fully automatic operation.
- QuickTree® technology allows quick inspection and removal of float switch without disconnecting the plumbing.
- Oil-filled motor with thermal-overload protection.
- Corrosion-resistant polyolefin basin with integrally molded rubber gasket for a superior gas-tight seal.
- Maintenance-free, permanently lubricated sealed bearings.
- 10' power cord with ground plug
- 3/8" Solids-Handling
- 1/2 hp

Maximum fluid temperature 180 degrees F.

Not intended for use with chemicals.

### APPLICATIONS:

- Laundry Trays
- Commercial Sinks
- Bar Sinks
- Dishwashers
- Dehumidifiers
- Wherever gray wastewater drainage is needed below gravity lines.

Specifically designed for higher head applications such as commercial and industrial buildings.

### DIMENSIONAL DATA:

Weight: 16 LBS.

Major Height: 14-1/8"

Major Width: 13-3/4"

Inlet Height (from bottom of basin): 12-5/8"

Total Capacity: 5.5 Gallons

Inlet Size: 2"

Discharge Size: 2"

Vent Size: 2"

### PERFORMANCE CURVE 60 hz

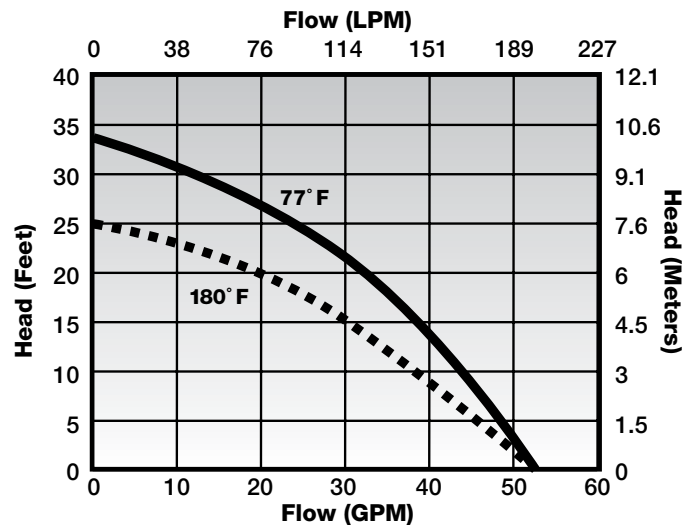

MODEL	HP	Volts	Amps	Discharge, Inlet & Vent	Alarm
405	1/2	115	7.3	2"	No
405/A	1/2	115	7.3	2"	Standard Alarm
405/A-EYE	1/2	115	7.3	2"	NightEye® Wireless
405HV	1/2	230	3.5	2"	No

Alarmed models come with factory mounted alarm float in system. No assembly required.  
See Alarm literature for ALM-2 standard alarm or NightEye® Wi-Fi alarm for complete alarm specifications.

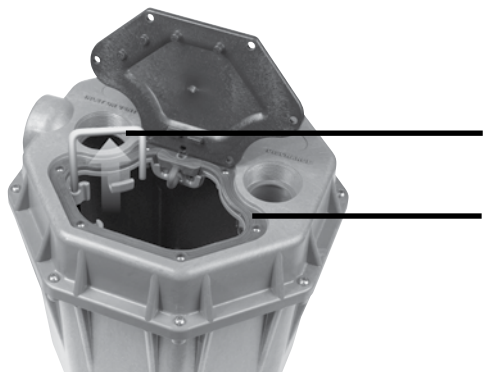

QuickTree® technology allows easy removal of float without disconnecting plumbing or pulling the pump

Heavy-Duty integrally molded rubber gasket provides a superior seal.  
Meets 10' stack test requirements.



Specifications are subject to change without notice.