

9SC SERIES - 4/10 HP

APPLICATIONS

Sewage and effluent wastewater transfer, dewatering

FEATURES

- Permanent Split Capacitor (PSC)
- Energy-saving low amp draw
- Designed for continuous duty
- 2" FNPT (51 mm) discharge
- Handles solids up to 2" (51 mm) diameter
- Multiple switch options for automatic operation
- 140 °F (60 °C) liquid temperature rating
- cCSAus listed



SERIES SPECIFICATIONS

Model	HP	Volts	Hz	Amps	Watts	Max. Water Temp.	GPM / Liters per Minute @ Height			Shut-Off	
							5 ft (1.5 m)	10 ft (3 m)	15 ft (4.6 m)	ft (m)	PSI (Bar)
9SC	4/10	115	60	8	870	140 °F (60 °C)	100 / 379	80 / 303	60 / 227	20 (6.1)	8.7 (0.60)

Item No.	Model	HP	Volts	Discharge	Switch Type / Operation	On Level	Off Level	Cord	Weight
509411	9SC-CIA-SFS	4/10	115	2"	Integral Snap-Action Float	10" - 13" 25 cm - 33 cm	5" - 8" 13 cm - 20 cm	20' 6.1 m	38.5 lbs 17.5 kg
509412	9SC-CIA-RF	4/10	115	2"	Piggyback Mechanical Float	16" - 19" 41 cm - 48 cm	9" - 11" 23 cm - 28 cm	20' 6.1 m	38.4 lbs 17.4 kg
509413	9SC-CIM	4/10	115	2"	Manual	-	-	20' 6.1 m	36 lbs 16.3 kg

SEWAGE PUMPS

9SC SERIES - 4/10 HP

ENGINEERING DATA

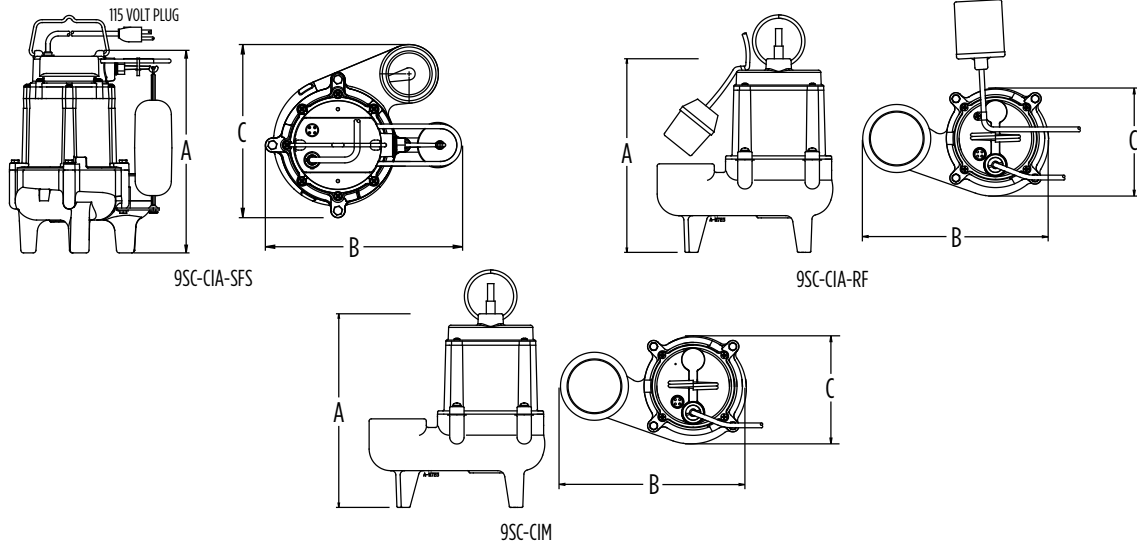

Model	A	B	C
9SN-CIA-SFS	14.4" (366 mm)	10.7" (273 mm)	8.6" (219 mm)
9SN-CIA-RF	13.6" (346 mm)	10.4" (264 mm)	8.6" (219 mm)
9SN-CIM	13.6" (346 mm)	10.4" (264 mm)	8.6" (219 mm)

PERFORMANCE DATA

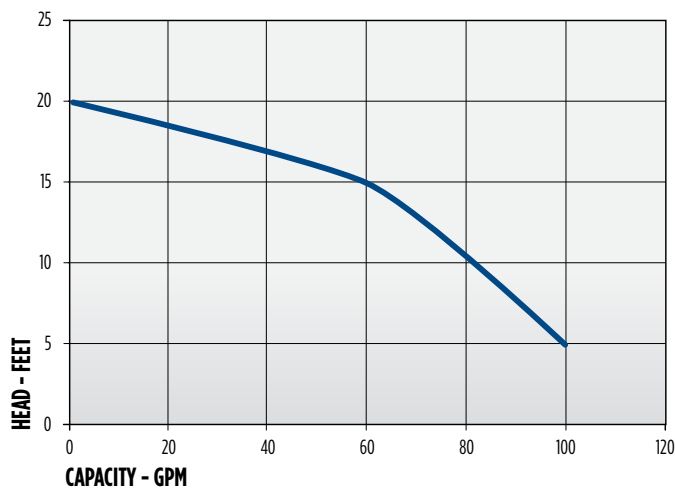

CONSTRUCTION

Cover	Epoxy-coated cast iron/ *Thermoplastic
Motor Housing	Epoxy-coated cast iron
Impeller Material	Nylon
Impeller Type	Vortex
Volute	Epoxy-coated cast iron
Mechanical Shaft Seal	Nitrile with carbon and ceramic faces
Fasteners	Stainless steel
Shaft	Steel
Bearings	Upper sintered sleeve and lower ball bearings
Power Cord	SJTW **SJTOW

* On SFS models

** On 30' 9SC-CIA-RF and 9SC-CIM models