

BSP50 SERIES - 1/2 HP

APPLICATIONS

- Basement sump applications or clear wastewater removal especially for new builder installations

FEATURES

- Cast aluminum motor housing and thermoplastic design – Keeps weight down and temperatures low for long life
- Oil Filled PSC motor – Provides plenty of power and efficiency
- Screened top volute intake – Prevents picking up debris from the basin floor that could cause clogging or damage
- Upper and lower ball bearings – Provides quiet and more robust operation
- 95°F (35°C) liquid temperature rating – Gives application flexibility
- cCSAus
- 1-1/2" FNPT discharge
- Vertical float switch - Reliable automatic pump operation



BSP50V



SERIES SPECIFICATIONS

Model	HP	Volts	Hz	Amps	Watts	Max. Water Temp.	GPM / Liters per Minute @ Height				Shut-Off	
							5' 1.5 m	10' 3 m	15' 4.6 m	20' 6 m	ft / m	PSI / Bar
BSP50V	1/2	115	60	6.5	550	95°F (35°C)	53/201	45/170	35/132	21/79	26/7.9m	11.2/0.77

Item No.	Model	HP	Volts	Switch Type / Operation	On Level	Off Level	Cord	Weight (lbs/kg)
511251	BSP50V	1/2	115	Piggyback Vertical Float	6.3"-8.3"/16 cm-20.3 cm	1.8"-3.8"/4.6 cm-9.7 cm	8'	8.6/3.9

SUMP PUMPS

BSP50 SERIES - 1/2 HP

ENGINEERING DATA

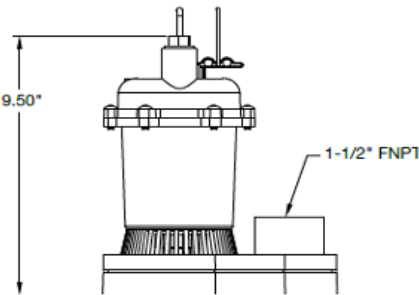
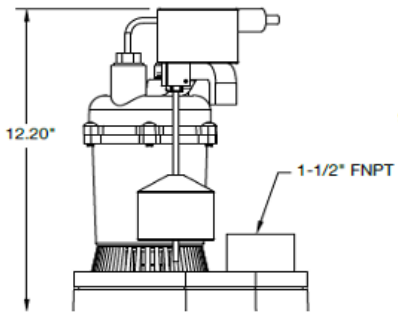
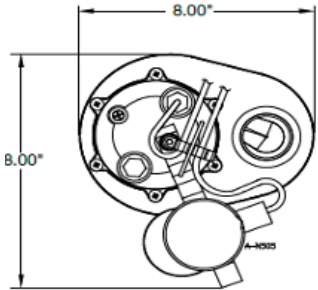

PERFORMANCE DATA

Sump/Effluent Pump Composite Performance Curves

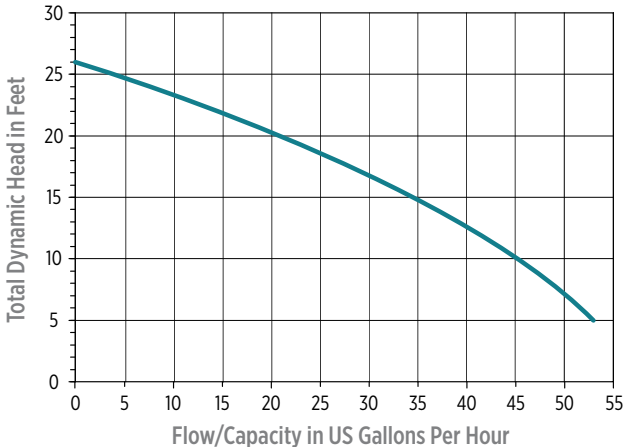

CONSTRUCTION

Cover	Thermoplastic
Motor Housing	Epoxy Coated Cast Aluminum
Impeller Design	Vortex
Impeller Material	Thermoplastic
Volute	Thermoplastic
Mechanical Shaft Seal	Carbon/Ceramic/Nitrile
Fasteners	Stainless Steel
Shaft	Stainless Steel
Bearings	Upper and Lower Ball Bearings
Power Cord	SJTW

