

Accessories Installation Instructions

Cord Seal, Cable Weight, Cable Clamp Assembly, and Float Bracket.

CORD SEALS



Provides strain relief and a liquid-tight seal.

- Seals 1-4 cables in 2" terminal adapters
- Seals 1-6 cables in 2½" terminal adapters
- PVC plugs included (for unused cable positions)
- Ground wire

CABLE WEIGHT



U.S. Patent 5,306,885

Provides an accurate pivot point for suspended float switches.

- Gripper teeth on clip and weight channel securely lock float cable into place
- Cable Weight can be adjusted without the use of tools

CABLE CLAMP ASSEMBLY



Provides cable anchor point and strain relief. Secures cable in vertical direction.

- For use with 18/16 gauge, 14 gauge, & 12 gauge cable
- Mounting clamp: ABS Nylon blend
- Hose clamp: highly corrosion resistant stainless steel

FLOAT BRACKET

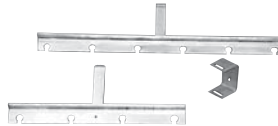

Provides convenient installation of float switches.

- Six Float Bracket supports 1-6 floats
- Four Float Bracket supports 1-4 floats
- Can be directly mounted to wall or used with wall mounting device
- Provides convenient location to stow excess float cord
- Supplied with cord strain relief connectors

PREVENTATIVE MAINTENANCE

- Periodically inspect the product. Check that the cable has not become worn or that the housing has not been damaged so as to impair the protection of the product. Replace the product immediately if any damage is found or suspected.
- Periodically check to see that the float is free to move and operate the pump or alarm.
- Use only SJE-Rhombus® replacement parts.

SJE-RHOMBUS® FIVE-YEAR LIMITED WARRANTY

SJE-RHOMBUS® warrants to the original consumer that this product shall be free of manufacturing defects for five years after the date of consumer purchase. During that time period and subject to the conditions set forth below, SJE-RHOMBUS® will repair or replace, for the original consumer, any component which proves to be defective due to defective materials or workmanship of SJE-RHOMBUS®.

THIS EXPRESS WARRANTY DOES NOT APPLY TO THE MOTOR START KIT COMPONENT. SJE-RHOMBUS® MAKES NO WARRANTIES OF ANY TYPE WITH RESPECT TO THE MOTOR START KIT.

ELECTRICAL WIRING AND SERVICING OF THIS PRODUCT MUST BE PERFORMED BY A LICENSED ELECTRICIAN.

THIS WARRANTY DOES NOT APPLY: (A) to damage due to lightning or conditions beyond the control of SJE-RHOMBUS®; (B) to defects or malfunctions resulting from failure to properly install, operate or maintain the unit in accordance with printed instructions provided; (C) to failures resulting from abuse, misuse, accident, or negligence; (D) to units which are not installed in accordance with applicable local codes, ordinances, or accepted trade practices, and (E) to units repaired and/or modified without prior authorization from SJE-RHOMBUS®.

Some states do not allow limitations on how long an implied warranty lasts, so the above limitation may not apply to you. Some states do not allow the exclusion or limitation of incidental or consequential damages, so the above limitation or exclusion may not apply to you. This warranty gives you specific legal rights, and you may also have other rights which vary from state to state.

TO OBTAIN WARRANTY SERVICE: The consumer shall assume all responsibility and expense for removal, reinstallation, and freight. Any item to be repaired or replaced under this warranty must be returned to SJE-RHOMBUS®, or such place as designated by SJE-RHOMBUS®.

ANY IMPLIED WARRANTIES OF MERCHANTABILITY OR FITNESS ARE LIMITED TO THE DURATION OF THIS WRITTEN WARRANTY. SJE-RHOMBUS® SHALL NOT, IN ANY MANNER, BE LIABLE FOR ANY INCIDENTAL OR CONSEQUENTIAL DAMAGES AS A RESULT OF A BREACH OF THIS WRITTEN WARRANTY OR ANY IMPLIED WARRANTY.

NOTICE!

Products returned must be cleaned, sanitized, or decontaminated as necessary prior to shipment to ensure that employees will not be exposed to health hazards in handling said material. All applicable laws and regulations shall apply.

⚠ WARNING**ELECTRICAL SHOCK HAZARD**

Disconnect power before installing or servicing this product. A qualified service person must install and service this product according to applicable electrical and plumbing codes.

⚠ WARNING**EXPLOSION OR FIRE HAZARD**

Do not use this product with flammable liquids. Do not install in hazardous locations as defined by National Electrical Code, ANSI/NFPA 70.

Failure to follow these precautions could result in serious injury or death. Replace product immediately if switch cable becomes damaged or severed. Keep these instructions with warranty after installation. This product must be installed in accordance with National Electric Code, ANSI/NFPA 70 so as to prevent moisture from entering or accumulating within boxes, conduit bodies, fittings, float housing, or cable.

For detailed specifications on this product, or for the complete line of SJE-Rhombus® panel, alarm, and switch products, visit our web-site at www.sjrhombus.com.

CORD SEAL INSTALL

1. Pass the cables through the 2" or 2½" terminal adaptor.
2. Route cables through the seal, leaving adequate cable to work with. See **Figure A**.
NOTE: If all hole positions are not used, plug open position(s) in the cord seal with the PVC plug(s) provided.
3. Insert the cord seal into the terminal adaptor and tighten hex nut until adequate strain relief is achieved.
4. Gather all ground wires, including ground conductor on the cord seal and secure to ground terminal.

CABLE WEIGHT INSTALL

1. Lay cable in weight as shown in **Figure B**.
2. Align clip with weight groove and slide clip towards cable as shown in **Figure B**. Snap clip snugly up to cable and manually force clip to tightest possible position.
3. See **Figure C** for proper tether length.

CABLE CLAMP INSTALL

1. Determine the required cord tether length according to product specifications.
2. Place the cord into the clamp as shown as shown in **Figure D**.
3. Locate clamp at desired activation level and secure the clamp to the discharge pipe as shown in **Figure D**.
Note: Do not install cord under hose clamp.
4. Tighten the hose clamp using screwdriver. Over tightening may result in damage to the plastic clamp. Make sure the float cable is not allowed to touch the excess hose clamp band during operation.
5. Wire switch as shown in the Wiring Diagrams.
6. Check installation. Allow system to cycle to insure proper operation.

Note: All hose clamp components are made of 18-8 stainless steel material. See your SJE-Rhombus® supplier for replacements.

FLOAT BRACKET INSTALL

1. Drill holes in mounting surface 1-5/16 inches apart.
2. Install float bracket mounting device as shown in **Figure E**.
NOTE: Use stainless steel fasteners appropriate for the mounting surface.
3. Determine float switch cord length to hang into tank to achieve proper activation level.
4. Install float switch cords to float bracket using strain relief connectors as shown in **Figure F**.
5. Install float bracket into float bracket mounting device while stowing excess cable as shown in **Figure F**.

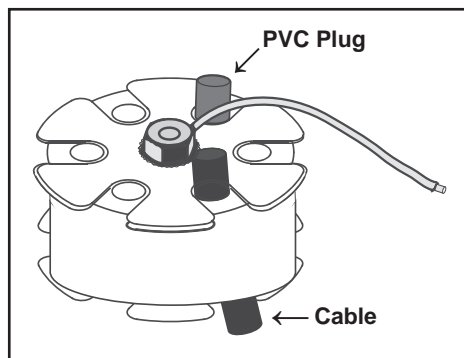
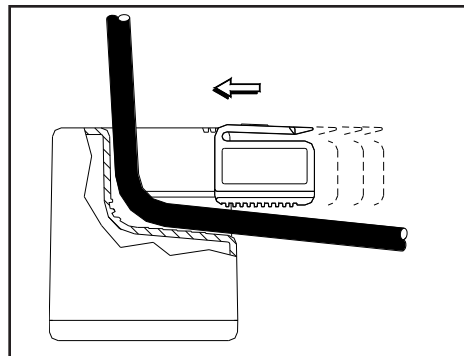
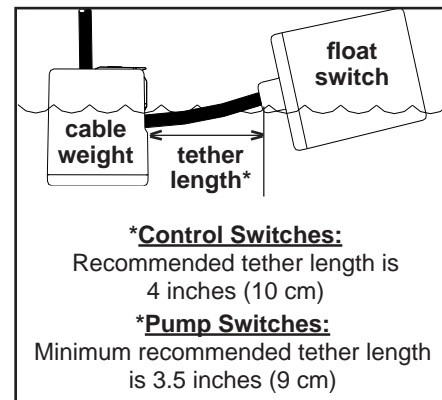
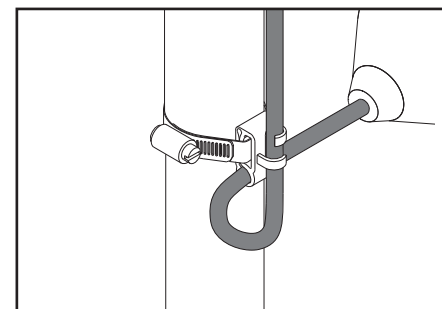
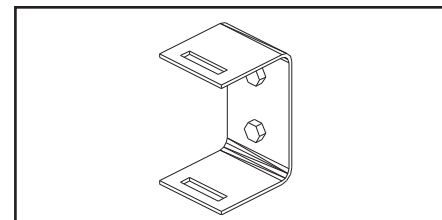
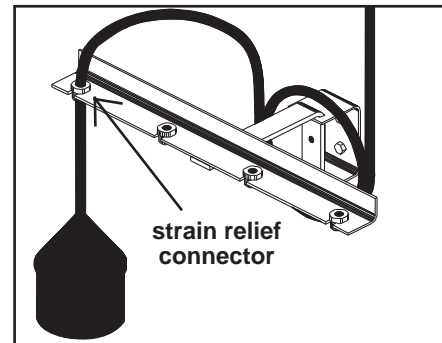
Figure A**Figure B****Figure C****Figure D****Figure E****Figure F**

SJE-Rhombus®

22650 County Highway 6 ■ P.O. Box 1708 ■ Detroit Lakes, Minnesota 56502 USA

1-888-DIAL-SJE (1-888-342-5753) ■ Phone: 218-847-1317 ■ Fax: 218-847-4617 ■ E-mail: customer.service@sjrhombus.com