



SW-120V-1L & 2L Sump Alarm High Water Alarm and Monitor

www.SumpAlarm.com

Contact: CustomerService@SumpAlarm.Com 314-787-8059

This documentation is applicable to Sump Alarm part numbers starting with SW-120V-1L/XX and SW-120V-2L/XX

The Sump Alarm High Water Alarm and Monitor is **designed for outdoor use, sun, rain, temperature resistance, and contains only Long Life LED Pilot lights**. Your Sump Alarm carries a 3 year LIMITED warranty from the date of purchase, defined below.

Sump Alarm activates when the water level in the basin or sump rises above the desired level. The alarm system includes a red LED beacon with integrated audible alarm buzzer.

The high level alarm system will automatically reset when the high level condition is corrected. The enclosure is weatherproof to allow outdoor installation and has a flammability rating which meets UL 94-5V. **Figure 1** (at right) shows the front of the Sump Alarms to which this documentation applies.

Read and follow all instructions and safety guidelines thoroughly before installing or operating the system. Failure to follow the instructions could result in serious bodily injury or death and/or property/pump damage.



Figure 1 – 2L & 1L Head Unit



SAFETY GUIDELINES

WARNING: DISCONNECT ALL POWER BEFORE INSTALLING OR SERVICING THE PUMP OR THE SUMP ALARM!

1. Read and follow all safety guidelines and installation/operation instructions.
2. Follow all national, state or provincial, and local building, plumbing and electrical codes and ordinances.
3. Do not install or operate the Sump Alarm while standing on a wet or damp surface.
4. Do not energize the head unit if an electrical component is damaged or appears damaged or the head unit is open.
5. Do not energize if there are wires disconnected or which appear loose, frayed, or damaged.
6. Be certain to close the head unit to protect other against potential electrical shock, and maintain moisture outside of the Sump Alarm head unit.
7. Do not install the unit in locations classified as hazardous in accordance with the most recent National Electrical Code.
8. Follow all installation/operation instructions and safety guidelines accompanying the grinder pumps and/or basin system.

LOCATING & MOUNTING THE SUMP ALARM HEAD UNIT

The Sump Alarm should be mounted in a convenient location. Cable lengths need to be considered, and extra float switch cable can be stowed above or below the water line. The head unit location should allow “line-of-sight” visibility of the indicating light from the desired vantage point. The sound is directional, and like the light, should be pointed to a designated location.

The Sump Alarm should be securely mounted to a wall or secure vertical structure which is free of vibration. The 1L Sump Alarm has two mounting holes, and the 2L will have 4. The mounting holes can be accessed by removing the face plate. Mounting screws have been included for your convenience. Should screws of a different length be required, utilize a #8 Pan Head screw. **A NOTE ON POWERDRILLS: Put your drill at the lowest torque setting to avoid stripping the plastic receivers. A torque setting of 4 is recommended.**

Note that the weather proof mounting holes can be accessed by opening the head unit and are directly adjacent to the posts for mounting the face of the head unit.

Access Positions for Mounting Holes inside the Unit

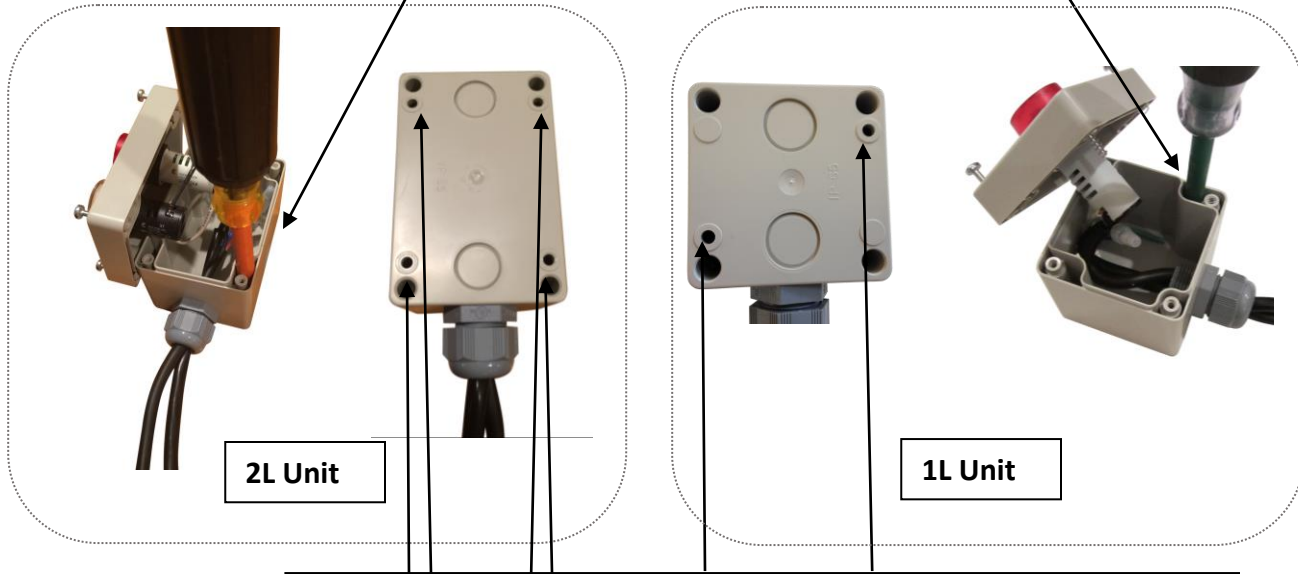

2L Unit

1L Unit

Templates are below to drill holes matching the Mounting Holes on Backside of the Enclosure

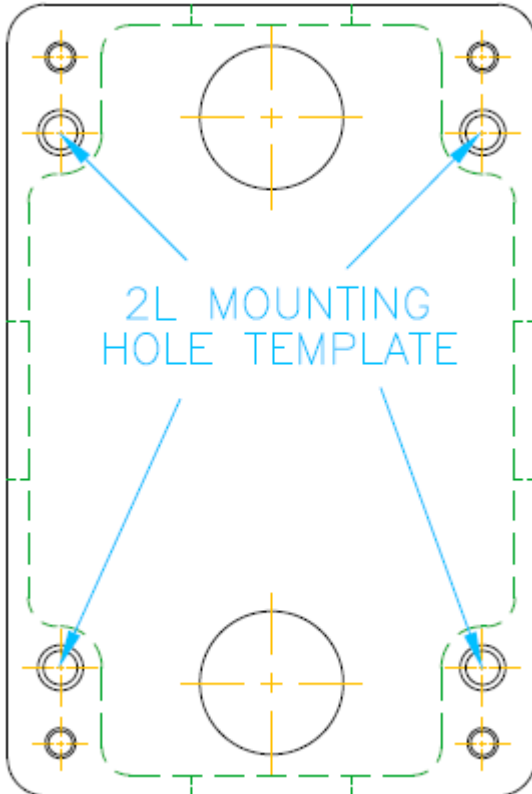

These diagram are scaled hole pattern templates for mounting. A 1/8" drill bit is recommended.

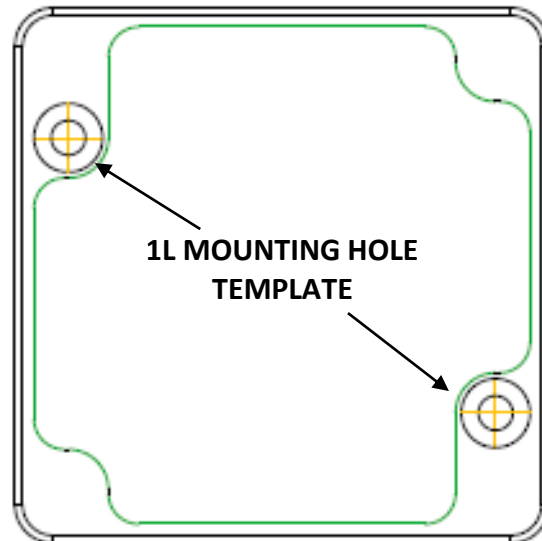

MOUNTING FLOAT SWITCHES

Sump Alarm is equipped with a float switch. Positioning and installation of the float switches is application dependent and will require consideration by you, the user.

The ALARM sensor should be positioned to activate (swing up) when the water level rises past normal, and swing down to a 'hanging rest' position during normal operation. The float cable can be zip-tied to a specific location (such as the pump discharge pipe), or can hang into the sump and pivot around the counterweight on the cable.

Mounting the Counterweight on the Cable (if required)

Your installation may or may not require the use of the counterweight included in the shipment. **Note: The cable weight is not intended to submerge the float switch. It is designed to orient your float switch such that it is vertical when the water level is high.**

You may elect to simply zip tie the float switch cord to the pump discharge, the pump itself, or the sump wall. The cable weight will be necessary if the float is hanging into the water anchored at the top of the tank or sump.

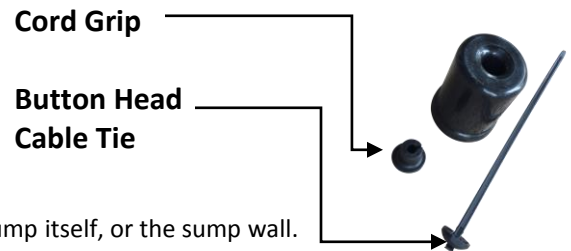

The cable weight can be applied to the cable using the Button head cable tie included in your shipment. If not already installed, slide the empty cord grip into the counterweight. Pass the button head cable tie through the cord grip until it emerges from the bottom of the counterweight. Circle around the cable and bring the end of the cable tie back through the button head where the cable tie originates. Walk the cable through the button head until it is taught. Trim the extra cable tie when complete.



Once installation is complete, position your float in the sump and TEST it in the final location. When the float switch drifts above the counterweight (or the point to which it is affixed), the switch closes and the alarm sounds. When it returns below the counterweight (or fixation point), the switch will open. The float must be free to rise and fall without interference. A minimum of 3" of cable is recommended between the float switch and counterweight.

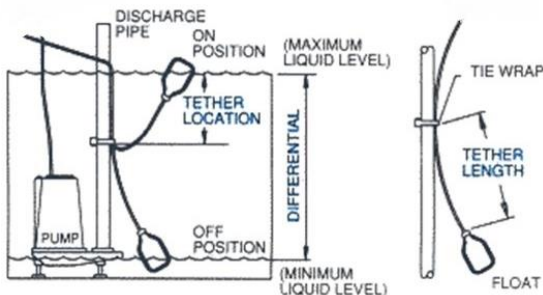

The Float switch will need to be positioned in the sump and TESTED in its final location in order to fill it's intended function.



SW-120V-1L & 2L Sump Alarm High Water Alarm and Monitor

www.SumpAlarm.com

Contact: CustomerService@SumpAlarm.Com 314-787-8059

TESTING THE UNIT

1. If not already complete, with POWER OFF mount the head unit, adjust the counterweight, and position or mount the float switch to sense high level.
2. Plug SUMP ALARM into a 120V power supply.
3. **FILL THE SUMP, POND, or cause a high-level condition** using a hose or other means. STOPPING or unplugging the pump may be required. Observe the float switch rise as the level increases.
4. **CONFIRM THAT THE RED LIGHT ILLUMINATES AND HORN SOUNDS.** If not, adjust the counterweights and or cable anchoring such that the floats are active when the sump or tank is full.
5. Allow the level to lower using the pump or other means. As the water drains:
 - a. The RED "HIGH WATER ALARM LIGHT" should turn OFF, and AUDIBLE ALARM will STOP.
 - b. The cables should return to their original position without dragging or catching.
6. IT IS SUGGESTED TO FILL AND EMPTY THE SUMP SEVERAL TIMES and ensure the float switches are properly located, with the correct range of motion, and cables are free from any obstacles.

After the TESTING check has been completed, the unit is ready for operation.

Note: Common causes of HIGH WATER ALARM include:

1. Dirt, leaves, rocks, sticks, and other debris are blocking the pump inlet.
2. The pump has been angled or turned over by the presence of the above and the level switch is permanently submerged.
3. The discharge of the pump is blocked or restricted (including frozen)
4. The pump is undersized for the application (generally a new pump which runs constantly)
5. The lower level switch is not operating properly, or is stuck.
6. The bearings or impeller internal to the pump are worn

The light is an indicator to investigate these conditions, note that only condition #6 requires work to the pump, the others would continue indefinitely and would continue to exist in many cases even if the pump were replaced.

LIMITED THREE YEAR WARRANTY

Sump Alarm, Inc. warrants to the original consumer that this product shall be free of manufacturing defects for three years after the date of consumer purchase. During that time period and subject to the conditions set forth below, Sump Alarm, Inc. will repair or replace, for the original consumer, any component which proves to be defective due to the materials or workmanship of Sump Alarm, Inc.

This warranty does not apply: (a) to damage due to lightning or conditions beyond the control of Sump Alarm, Inc. (b) to defects or malfunctions resulting from failure to properly install, operate, or maintain the unit according with the instructions provided; (c) to failures resulting from the abuse, misuse, accident or negligence; (d) to units which are not installed in accordance with applicable local codes, ordinances or accepted trade practices, and (e) to units repaired and/or modified without the authorization of Sump Alarm, Inc. To obtain warranty service: The consumer shall assume all responsibility and expense for removal reinstallation and freight.

ANY IMPLIED WARRANTIES OF MERCHANTABILITY OR FITNESS ARE LIMITED TO THE DURATION OF THIS WRITTEN WARRANTY. SUMP ALARM, INC. SHALL NOT, IN ANY MANNER, BE LIABLE FOR ANY INCIDENTAL OR CONSEQUENTIAL DAMAGES AS A RESULT OF A BREACH OF THIS WRITTEN WARRANTY OR ANY IMPLIED WARRANTY.